



Всеукраїнський науково-технічний журнал

All-Ukrainian Scientific & Technical Journal

ISSN 2520-6168 (Print)

Machinery
Energetics
Transport
of Agribusiness



ТЕХНІКА
ЕНЕРГЕТИКА
ТРАНСПОРТ АПК



**ТЕХНІКА,
ЕНЕРГЕТИКА,
ТРАНСПОРТ АПК**

Журнал науково-виробничого та навчального спрямування
Видавець: Вінницький національний аграрний університет

Заснований у 1997 році під назвою «Вісник Вінницького державного сільськогосподарського інституту».
Правонаступник видання: Збірник наукових праць Вінницького національного аграрного університету. Серія: Технічні науки.
Свідоцтво про державну реєстрацію засобів масової інформації
КВ № 16644–5116 ПР від 30.04.2010 р.

*Всеукраїнський науково – технічний журнал «Техніка, енергетика, транспорт АПК» /
Редколегія: Калетнік Г.М. (головний редактор) та інші. – Вінниця, 2018. – 1 (100) – 165 с.*

*Друкується за рішенням Вченої ради Вінницького національного аграрного університету
(протокол 11 від 12.04.2018 р.)*

Свідоцтво про державну реєстрацію засобів масової інформації №21906-11806 Р від 12.03.2016р.

*Журнал є друкованим засобом масової інформації, який внесено до переліку наукових фахових
видань України з технічних наук (Додаток 12 до наказу Міністерства освіти і науки України
16.05.2016 № 515).*

Головний редактор

Калетнік Г.М. – д.е.н., проф., академік НААНУ,
Вінницький національний аграрний університет

Заступник головного редактора

Матвійчук В.А. – д.т.н., проф., Вінницький
національний аграрний університет

Члени редакційної колегії

Анісімов В.Ф. – д.т.н., проф., Вінницький
національний аграрний університет

Іскович – Лотоцький Р.Д. – д.т.н., проф.,
Вінницький національний технічний університет

Огородніков В.А. – д.т.н., проф., Вінницький
національний технічний університет

Бурдо О.Г. – д.т.н., проф., академік АНТКУ,
Одеська національна академія харчових
технологій

Гулько І.В. – к.т.н., доц., Вінницький
національний аграрний університет

Бандура В.М. – к.т.н., доц., Вінницький
національний аграрний університет

Булгаков В.М. – д.т.н., проф., академік НААН,
Національний університет біоресурсів і
природокористування України

Солона О.В. – к.т.н., доц., Вінницький національний
аграрний університет

Іванов М.І. – к.т.н., проф., Вінницький національний
аграрний університет

Кондратюк Д.Г. – к.т.н., доц., Вінницький
національний аграрний університет

Любін М.В. – к.т.н., доц., Вінницький національний
аграрний університет

Пришляк В.М. – к.т.н., доц., Вінницький
національний аграрний університет

Серета Л.П. – к.т.н., проф., Вінницький національний
аграрний університет

Веселовська Н.Р. – д.т.н., проф., Вінницький
національний аграрний університет

Гевко Р.Б. – д.т.н., проф., Тернопільський
національний економічний університет

Зарубіжні члени редакційної колегії

Володимир Крочко – д.т.н., проф., Словацький
аграрний університет (м. Нітра, Словаччина)

Януш Новак – д.т.н., проф., Люблінський
аграрний університет (м. Люблін, Польща)

Маріан Веселовські – д.т.н., проф.,
Люблінський природничий університет
(м. Люблін, Польща)

Зденко Ткач – д.т.н., проф., Словацький
аграрний університет (м. Нітра, Словаччина)

Семенс Івановс – д.т.н., проф., Латвійський
аграрний університет (м. Улброка, Латвія)

Людвікас Шпокас – д.т.н., проф., Університет
Олександра Стулгинського (Литва)

Марош Коренко – д.т.н., проф., Словацький аграрний
університет (м. Нітра, Словаччина)

Ян Франчак – д.т.н., проф. Словацький аграрний
університет (м. Нітра, Словаччина)

Володимир Юрча – д.т.н., проф., Чеський
університет сільського господарства (м. Прага, Чехія)

Гражина Езевська-Вітковська – д.т.н., проф.,
Люблінський аграрний університет (м. Люблін,
Польща)

Відповідальний секретар редакції **Янович В.П.** кандидат технічних наук, доцент

Адреса редакції: 21008, Вінниця, вул. Сонячна 3, Вінницький національний аграрний університет, тел. 46–00–03

Сайт журналу: <http://tetapk.vsau.org/>

Електронна адреса: tehnovnu@i.ua

**ЗМІСТ****I. МАШИНОВИКОРИСТАННЯ У РОСЛИННИЦТВІ ТА ТВАРИННИЦТВІ***Мазур В.А., Любін М.В., Токарчук О.А.***ОСНОВИ ЄВРОПЕЙСЬКИХ ТЕХНОЛОГІЙ ВИРОЩУВАННЯ КОРМОВИХ БУРЯКІВ ТА ДОСЛІДЖЕННЯ ПРОЦЕСУ ЇХ ПОДРІБНЕННЯ.....5***Погорілий С.П., Черняк Р.Є., Дунь С.В.***ДОСЛІДЖЕННЯ ТЯГОВИХ ПОКАЗНИКІВ МЕЗ-330 «АВТОТРАКТОР»19****II. ТЕХНІЧНИЙ СЕРВІС МОБІЛЬНОЇ ТЕХНІКИ***Барановський В.М., Спірін А.В., Полевода Ю.А., Твердохліб І.В.***РОЛЬ І МІСЦЕ ТЕХНІЧНОГО ДІАГНОСТУВАННЯ В СИСТЕМІ ТЕХНІЧНОЇ ЕКСПЛУАТАЦІЇ АВТОМОБІЛІВ В СІЛЬСЬКОМУ ГОСПОДАРСТВІ24***Денисюк В.О.***РЕАЛІЗАЦІЯ СТЕГАНОГРАФІЧНОГО АЛГОРИТМУ ЗАХИСТУ ДАНИХ З ВИКОРИСТАННЯМ ФАЙЛІВ ЗОБРАЖЕНЬ.....29***Тихонов Ю.Л.***МАТЕМАТИЧНИЙ ОПИС ПРОЦЕСІВ В Е-ОСВІТІ.....39****III. ПРОЦЕСИ ТА ОБЛАДНАННЯ ПЕРЕРОБНИХ ТА ХАРЧОВИХ ВИРОБНИЦТВ***Ковбаса В.П., Солоня О.В., Спірін А.В., Цуркан О.В.***ПРО СПРОЩЕННЯ КРИТЕРІЮ ВИГЛЯДУ НАПРУЖЕНО-ДЕФОРМОВАНОГО СТАНУ СУЦІЛЬНОГО СЕРЕДОВИЩА.....44***Фіалковська Л.В., Пазюк В.М.***ВИКОРИСТАННЯ ВІДХОДІВ РАФІНАЦІЇ ОЛІЇ50***Яропуд В.М.***ТЕОРЕТИЧНІ ДОСЛІДЖЕННЯ ПРОЦЕСУ ФУНКЦІОНУВАННЯ ТЕПЛОУТИЛІЗАТОРА ДЛЯ ТВАРИННИЦЬКИХ ПРИМІЩЕНЬ55***Берник І.М.***ДОСЛІДЖЕННЯ В'ЯЗКОСТІ ДИСПЕРСНИХ СЕРЕДОВИЩ В УМОВАХ ЇХНЬОЇ ІНТЕНСИВНОЇ ОБРОБКИ..... 62***Дмитренко В.П.***ЕКСПЕРИМЕНТАЛЬНЕ ОБЛАДНАННЯ ДЛЯ ДОСЛІДЖЕННЯ ШНЕКОВОГО РОБОЧОГО ОРГАНА ЕКСТРУДЕРА.....68****IV. МАШИНОБУДУВАННЯ ТА МАТЕРІАЛООБРОБКА***Ляшенко Б.А., Николайчук В.Я., Ивченко Т.И., Михайлюта С.С.***ПОВЫШЕНИЕ РЕСУРСА ПОРШНЕЙ АВТОТРАКТОРНЫХ ДВИГАТЕЛЕЙ ЗА СЧЕТ ПРИМЕНЕНИЯ ТЕПЛОЗАЩИТНЫХ ПОКРЫТИЙ75****V. ЕНЕРГОТЕХНОЛОГІЇ ТА АЛЬТЕРНАТИВНІ ДЖЕРЕЛА ЕНЕРГІЇ***Шевчук О.Ф.***МЕТОДИ ВИМІРЮВАННЯ НЕЛІНІЙНИХ ДІЕЛЕКТРИЧНИХ ВЛАСТИВОСТЕЙ СЕГНЕТОЕЛЕКТРИЧНИХ РІДКИХ КРИСТАЛІВ84***Рубаненко О.Є., Рубаненко О.О., Гунько І.О.***ДОСЛІДЖЕННЯ СИСТЕМИ МОНІТОРИНГУ ПАРАМЕТРІВ РЕЖИМУ РОБОТИ СОНЯЧНОЇ ПАНЕЛІ.....91**



VI. ТРАНСПОРТНІ ТА ТРАНСПОРТНО - ТЕХНОЛОГІЧНІ ПРОЦЕСИ ТА ОБЛАДНАННЯ

Гевко І.Б., Клендій В.М., Слободян Л.М., Маруніч О.П., Залуцька Н.В.

ГВИНТОВИЙ ЗАВАНТАЖУВАЧ-ЗМІШУВАЧ З ЦЕНТРАЛЬНИМ ПРИВОДОМ.....99

Луців І.В., Гевко І.Б., Дубиняк Т.С., Гудь В.З.

**РЕЗУЛЬТАТИ ЕКСПЕРИМЕНТАЛЬНИХ ДОСЛІДЖЕНЬ ПРУЖНО-ЗАПОБІЖНОЇ МУФТИ
ГНУЧКОГО ГВИНТОВОГО КОНВЕЄРА..... 104**

Середа Л.П., Руткевич В.С., Зінєв М.В.

**STUDY OF THE MATHEMATICAL MODEL OF HYDRAULIC DRIVES SEGMENT-FINGER
MOWER UNIT..... 111**

Дубчак В.М., Новицька Л.М.

ЗАСТОСУВАННЯ МАТЕМАТИЧНОГО АПАРАТУ У ТРАНСПОРТНІЙ ЛОГІСТИЦІ АПК....123

Гуцько І.В., Січко Т.В., Ігнатов С.Н.

**АНАЛІЗ ОСОБЛИВОСТЕЙ ФУНКЦІОНУВАННЯ ІНТЕГРОВАНОЇ СИСТЕМИ ОБРОБКИ
СТАТИСТИЧНИХ ДАНИХ УКРАЇНИ 129**

Зелінська О.В.

**МЕТОДОЛОГІЯ ПРОЕКТУВАННЯ КОМП'ЮТЕРНИХ СИСТЕМ УПРАВЛІННЯ
ТЕХНОЛОГІЧНИМИ ПРОЦЕСАМИ В АПК 138**

VII. ДУМКА МОЛОДОГО ВЧЕНОГО

Самчук Ю.Ю.

**ЗАСТОСУВАННЯ КОМП'ЮТЕРНОГО МОДЕЛЮВАННЯ В ПРОЦЕСІ ОПТИМІЗАЦІЇ
КОНСТРУКТОРСЬКИХ РІШЕНЬ ПРИ ПРОЕКТУВАННІ ЗЕРНООЧИСНИХ МАШИН..... 144**

Денесяк Д.І.

НЕСТАЦІОНАРНИЙ ТЕПЛООБМІН У СИСТЕМІ «ВОДА-СТІНКА-В'ЯЗКА РІДИНА»152

Чайка Д.С.

**ОПРЕДЕЛЕНИЕ ПОКАЗАТЕЛЕЙ ПЛАСТИЧНОСТИ ВАЛЬЦУЕМЫХ ЗАГОТОВОК ИЗ
АЛЮМИНИЕВЫХ СПЛАВОВ В ОВАЛЬНЫХ КАЛИБРАХ 158**



UDC 621.22:62-522.2

STUDY OF THE MATHEMATICAL MODEL OF HYDRAULIC DRIVES SEGMENT-FINGER MOWER UNIT

Середа Леонід Павлович, к.т.н., професор
Руткевич Володимир Степанович, к.т.н., ст. викл.
Зінев Михайло Вікторович, асистент
Вінницький національний аграрний університет

L. Sereda, PhD, Full Professor
V. Rutkevych, PhD
M. Ziniev, Assistant
Vinnytsia National Agrarian University

Study will indicate the possibility of replacing mechanical drive segment-finger mower with the simple hydraulically function one, the simulation of dynamic processes occurring in the hydraulic drive system of segment-finger cutting unit. Describing of cutting process using a hydraulic drive segment-finger cutting unit. Creating mathematical model of the hydraulic drive and the results of its research. Based on the results of mathematical modeling it concluded that the mathematical model adequately reflects on the processes occurring in the hydraulic drive knives mower when specific load is applied to the working body and can be used for research in order to develop recommendations for the design and selection of optimum system parameters type.

Keywords: hydraulic, segment-finger cutter bar, mower, mowing, working body, dynamic loads, forces of inertia.

F. 48. Fig. 7. Ref. 9.

1. Introduction

Ukraine was, is and will remain the agro-industrial country in Eastern European area, the agricultural sector is one of the largest component of government budget. In order to preserve agricultural sector development with increasing global production level, we should implement world standards and trends. If we consider the agricultural sector of Ukraine in comparison with other agro-industrial countries, our crop production in some indicators can reached international indicators, while the animal continues to decline.

The actual situation of domestic livestock showing the need for radical changes in approach of production processes. Today difficult economic and foreign political relations with neighboring countries require total efficiency of livestock production to save the industry as a whole and to improve internal product safety. These problems can be successfully solved with constant modernization of technical resources and means of production including introduction of modern technologies and research results in the manufacturing process.

Slow development of livestock led to the inability to provide domestic needs in food industry. But due to inefficient farming, as calculated in Dairy Association, by the end of this year, Ukraine will cut 10-20% of cattle [1]. As a result of continuous reduction of livestock, milk production in Ukraine in 2015 decreased by 7% – to 10.4 million tons. Exports of dairy products decreased to 0.35 million tones of milk equivalent, imports reached – 0.15 million tons [1]. The presence of significant domestic demand for animal products encourages local farmers to restore the livestock industry as a whole, but the most complex area for recovery is our dairy industry. Creating a profitable livestock industry is impossible without introduction of modern mechanization and automation of manufacturing processes.

An important issue that must be addressed in the development of domestic livestock is providing high quality fodder. The main type of the feed for a cattle during cold season lasting 192 days a year, is roughage which includes hay from perennial grasses.

The main production process of harvesting this type of food is mowing. Today this process is fully mechanized. Significantly widely used rotary mowers are providing high speed cutting and can mow low to the ground grass, but they have a number of significant shortcomings - the increased consumption of energy per unit of work than the segment-finger mowing, low quality cut at mowing perennial legumes because of the destruction of basal stem plants, which ultimately can reduce the total number of slopes for the year, and thus to reduce the total amount of hay. As perennial legumes are the main crops of hay in industrial environments, the use of rotary mowers is inappropriate. The main disadvantage of using finger mowers have a significant dynamic imbalance of the cutting mechanism and the drive mechanism mowers, which in turn leads to lower productivity and in rapid wear of the mower. [2]



An important role in this matter can play implementation of hydraulic equipment for mowing finger. Up to this date, the use of hydraulic drives for process automation is no alternative. At the same time the domestic industry does not produce current finger mower with hydraulic working bodies. Therefore, this issue remains open for research.

2. Analysis of previous studies and publications

1 Generally different designs finger mowers have little differences in the design of the cutting part, the main differences relate to the layout of individual units and mechanisms block of the tractor, so replacing the mechanical drive for hydraulic drive is technologically simple process and can be performed in repair shops at any agricultural facilities or farm.

As noted in [2] Actuators job of mowing finger is the most important element of the design, and the most common excuse for cutting apparatus of the mowers reciprocating cutting part is a crank mechanism.

Because of its simplicity, it is widely used in other machines. Sometimes for providing reciprocating cam is used, but this leads to the faster deterioration of structural elements drive, so mowers with reciprocating working bodies, trying to use a simple crank mechanism which is lower kinematic pair.

However, the main drawback of this design is dynamic imbalance [3,4], crank and knives, equilibrium may be using balances performing oscillatory or rotational movement in the opposite, but it leads to increased weight and complexity of the design.

Malicious alternating loads leads to vibration, resulting appear harmful alternating stress in the joints and drive elements. The appearance of vibration reduces the maximum operating speed of the cutting mechanism, which in turn causes a decrease in operating speed and machine-unit productivity.

Most modern machines for agricultural purposes are made using hydraulic drive because of known benefits. Using hydraulic drive provides process automation, reducing fuel consumption by 15% [5], reducing dynamic loads, providing protection of workers against overload, reduces repair costs [6, 7].

Hydraulic equipment drive systems of active segment-fingers components are the most promising area of improvement [8]. Using hydraulic drive on all tractors, both domestic and foreign production will allow to use new mechanism with any level of energy method.

3. Formulation of the problem

The objectives of this study is to improve the design of hydraulic drive system of active mowing finger components. To provide fuel savings, cutting process automation, increased productivity, and reduced costs for repairs and maintenance mower by reducing harmful alternating loads on the drive mechanism, the task is solved by the proposing implementing hydraulic drive system.

4. Presentation of basic material

The most common design of the cutting apparatus finger mowers with reciprocating cutting element is a design based on the principle dezaksial crank mechanism kinematic scheme is shown in Figure 1 [2].

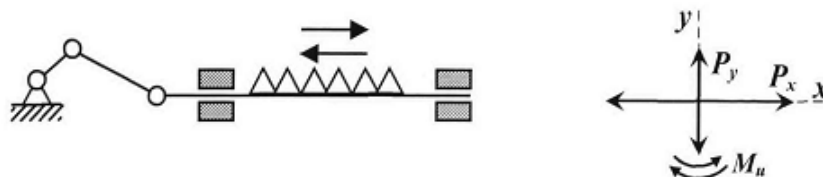

Fig. 1. The kinematics dezaksial crank mechanism drive the mower cutting apparatus

According to this principle designed mower KS-2,1A. This mower is widely used throughout the country, intended for mowing natural and seeded grasses in all soil-climatic zones, has a simple design, affordable, versatile, easy to use, has the ability to be aggregated with different power means traction class from 0.6 to 1.4 kN.

Cutting bar mowers shown in figure 2. It consists of a timber 11 moldboard blade 6 and 9. shelf digital beam consists of a tape on which fixed inner shoe outlet rod 2 of 3, 7 and outer shoe fingers with 4 blade support plates, friction plates, clamps the knife blade runners head. The knife blade is made of tape segments and head knife. Heaps rack 9 of 10 branching to the outer shoe via spring-loaded device.

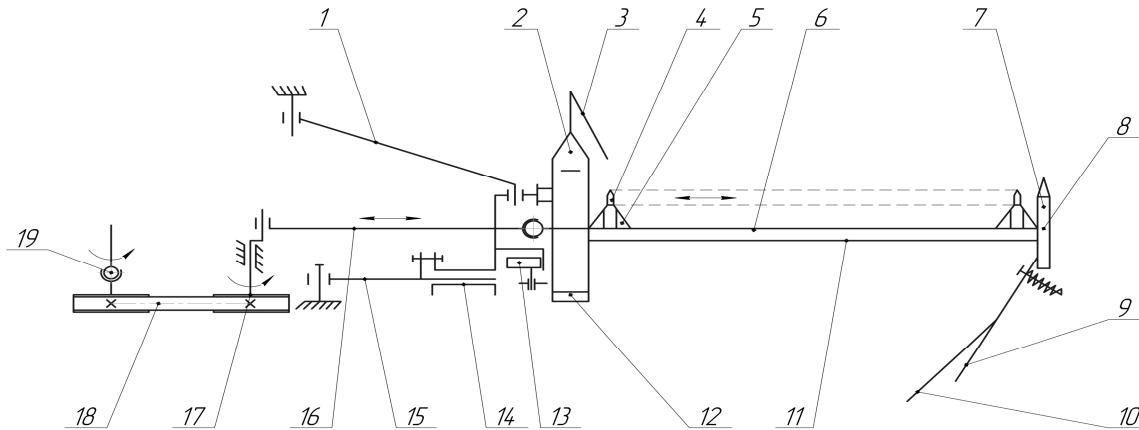

Fig. 2. Schematic diagram of the cutting apparatus mower KS-2,1A: 1 – stretching, 2 – shoe inside, 3 – bars, 4 – fingers, 5 – segments, 6 – than, 7 – shoe exterior, 8, 12 – slider, 9 – heaps shelf, 10 – stem out, 11 – finger beams, 13 – eccentric sleeve, 14 – main hinge, 15 – traction rod, 16 – rod, 17 – of the crank shaft, 18 – the crank finger belt drive, 19 – drive shaft

Actuators house consists of driving the drive shaft 19, which transmits torque of power means to the belt drive 18, which is used to partially compensate for alternating dynamic loads at the start of the work and to prevent damage to the cutting apparatus when entering into it metal objects or stones and with the crank shaft 17 with a finger and a rod 16.

To solve this problem we proposed to simplify the drive mechanism of the cutting apparatus mowing finger KS - 2,1A removing the drive shaft 19 and a belt drive 18 and crank shaft 17 with a finger and adapted connecting rod 16 driven by hydraulic motor.

In this regard, we suggested the following scheme hydraulic drive mower KS-2,1A which is shown in Figure 3.

Hydraulic scheme this works as follows. When transferring distributor lever 3 into position P1 pump delivers hydraulic fluid from the tank to the hydraulic motor power means 4, which shaft begins to rotate, resulting segments with the drive links are driven. Segments moving forward, lead plant to blade support edge of the plate and cut her finger. Surplus oil at low pressure (0.2-0.5 MPa) coming from the drainage hole in the tank tractor hydraulic motor on line 6.

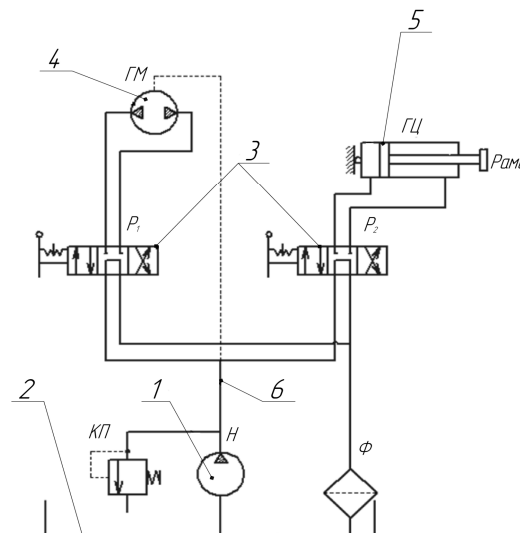

Fig. 3. Schematic diagram of the hydraulic mower unit: 1 – water pump, 2–hydro tank, 3–distributors, 4–hydraulic engine, 5–cylinder, 6–line forcing

If necessary, the implementation may reverse this lever distributor 3 R1neobhidno transfer to another work position, with the working fluid pressure drives the hydraulic motor shaft rotation in the opposite direction.

To convert the cutting machine with transport to work and back to the hydraulic cylinder mower



provided 5 which is guided by a similar valve 3 P2.

To prevent breakage of the cutting machine elements when hit by foreign objects, causing him stop, and, consequently, increased pressure in the hydraulic system, the hydraulic drive system provides a safety valve KP.

Investigation of work the hydraulic drive took place by mathematical modeling. Design model hydraulic drive machine cutting finger mower shown in Figure 4.

Design model shown in simplified form without lifting system elements mower in the transport position.

Hydraulic drive mower blade consists of a pumping station and hydraulic motor. Q_H consumption of the working fluid from the pumping station to the input hydraulic motor with a typical volume q_m . The elastic properties of the oral pipeline connecting a pumping station with a hydraulic motor, determined volume ratio compliance W_1 and $K_1(p_1)$, which depends on the inlet pressure p_1 hydraulic motor. The load on the hydraulic motor shaft GM determined point of the process load on the M_{mh} executive bodies crank mechanism and the inertial load. Summary moment of inertia of the moving parts work to the hydraulic motor shaft has a value of I. Elastic properties characterized drain line volume ratio compliance W_2 and $K_2(p_2)$, depending on the pressure at the outlet hydraulic motor – p_2 .

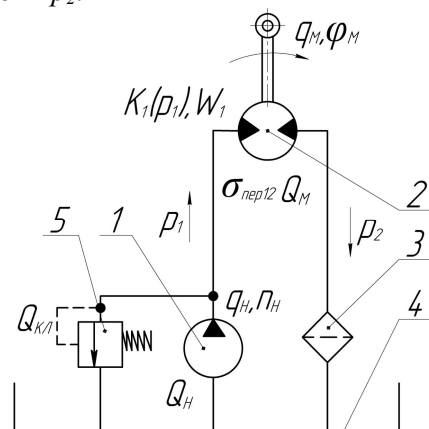

Fig. 4. Diagram of hydraulic drives the cutting machine: 1 – hydraulic pump, 2 – hydraulic motor, 3– filter, 4 – tank, 5 – relief valve

The working fluid pump 1 of the tank 4 is supplied in working cavity hydraulic motor 2. The fluid from the cavity through a hydraulic motor and distributor filter 3 is discharged into the tank 4. The safety valve prevents the destruction of the hydraulic system with increasing load.

Work mower blade drive continuity equation describes the flow of fluid, drawn up taking into account the balance of costs in the hydraulic system and the second kind Lagrange equation that describes the work of a crank mechanism.

In compiling a mathematical model taking into account the results of previous studies have taken such assumptions [9];

1. density, viscosity and cost factor working fluid does not depend on temperature through the system in steady temperature.
2. compliance factor is independent of fluid pressure and gas content component, as in the steady hydraulic mechanism its size varies slightly.
3. Pressure little backwater in the shower and the same.
4. Factor leaks and overflows of liquid components in hydraulic units is constant and does not depend on the size and shape of the slits.
5. The distance between the small hydraulic elements, allowing you to see it as a system with lumped parameters and does not consider the effect of wave processes.
6. ripple of the pump in view of its significant frequency excitation does not cause pressure fluctuations in the hydraulic system.
7. The fluid flow in gaps in joints Hydraulic components and hydraulic units has laminar nature.

To drive improved mathematical model mower blades includes the following equation.

The equations of fluid flow in arteries that connect the pump station and hydraulic engine according to the accepted assumptions provided a relatively small distance between the listed hydro-units be described model with lumped parameters, which in this case is a continuity equation of flow.



The equation of continuity the flow of the working fluid inlet hydraulic motor has the form:

$$Q_H = Q_M + Q_{\text{eum}.1} + Q_{\text{nep}.12} + Q_{\text{оef}.1} \quad (1)$$

where - Q_H the flow of fluid entering the hydraulic system of the pump, Q_M - flow rate through the first hydraulic motor, $Q_{\text{eum}.1}$ - leakage from hydraulic motor, $Q_{\text{nep}.1}$ - the cost of flow of fluid in the hydraulic motor under pressure differential p_1 and p_2 , $Q_{\text{оef}.1}$ - flow rate compensation deformation cavity under pressure p_1 .

Actual unregulated supply pump is determined by the expression

$$Q_H = q_n \cdot n_n \cdot \eta_{\text{оф}}, \quad (2)$$

where - q_n the working volume of the pump, n_n - the pump shaft speed, $\eta_{\text{оф}}$ - volumetric efficiency of the pump.

Fuel consumed by motors, determined expression.

$$Q_M = q_m(\phi_1) \cdot d\phi_1 / dt, \quad (3)$$

where - $q_m(\phi_1)$ typical volume hydraulic motor, $d\phi_1 / dt$ - angular speed hydraulic motor shaft rotation.

Losses to leak through the gaps calculated as the flow rate through the crack plane when adopted assumptions:

- form surfaces, forming a channel leakage, thoroughly;
- surface roughness note is not accepted.

In this case, the flow rate through the cross-section of the gap is given by

$$Q_{\text{eum}.1} = \sigma_1 \cdot p_1 \quad (4)$$

where - σ_1 carbon leakage of fluid from the cavity, which is under pressure.

Flows into hydro units with high-pressure chamber into the chamber through the low-pressure chambers incomplete tightness hydraulic units are defined by the following dependence p_1 .

$$Q_{\text{nep}.12} = \sigma_{\text{nep}.12} \cdot (p_1 - p_2), \quad (5)$$

where - $\sigma_{\text{nep}.12}$ coefficient of fluid flows between the cavities hydraulic motor according to the chamber pressure in low pressure chamber.

Costs arising during the deformation volume hydraulic drive cavities filled with fluid due to changes in pressure in these cavities, determined dependence

$$Q_{\text{оef}.1} = K_1(p_1) \cdot W_1 \cdot dp_1 / dt, \quad (6)$$

where $K_1(p_1)$ - ratio compliance respective routes and cavities of the hydraulic system, W_1 - capacity line from the pumping station to the entrance hydraulic motor.

Substituting expression (2), (3), (4), (5) and (6) in the expression (1) and obtain:

$$q_n \cdot n_n \cdot \eta_{\text{оф}} = q_m(\phi_1) \cdot \frac{d\phi_1}{dt} + \sigma_1 \cdot p_1 + \sigma_{\text{nep}.12} \times (p_1 - p_2) + K_1(p_1) \cdot W_1 \cdot \frac{dp_1}{dt}, \quad (7)$$

The load acting on the shaft of the hydraulic motor crank mechanism forward using Lagrange equations second kind. In general terms this equation for the generalized coordinates ϕ_1 is as follows

$$\frac{d}{dt} \frac{\partial}{\partial \dot{\phi}_1} T - \frac{\partial}{\partial \phi_1} T = F_{\phi_1}, \quad (8)$$

where T is the complete kinetic energy of the system, F_{ϕ_1} - is a generalized force.

The calculation scheme for determining the generalized force F_{ϕ_1} is shown in figure 5.

On the crank OA operates moment $M_{\text{оф}}$ from the hydraulic motor. The connecting rod AB carries a plane-parallel motion from the crank OA and provides a translational motion of the slider B. The moment of $M_{\text{оф}}$ is countered by the component of the cutting force Q_x , the frictional force that occurs in a pair of slide guides under the action of the component of the cutting force F_y , and the moment of liquid friction in the hydraulic motor.

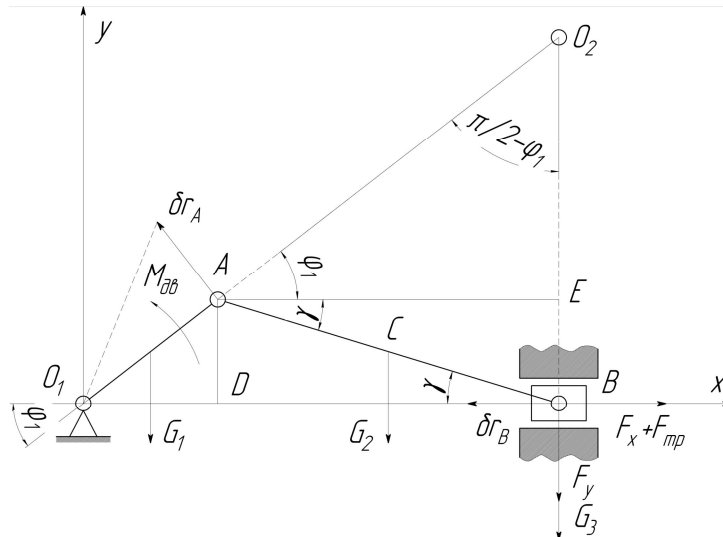

Fig. 5. Scheme of the crank mechanism for actuating the blades of a mower with a hydraulic drive

Calculate the generalized force acting on the crank mechanism, the calculation scheme of which is shown in Figure 5.

The sum of the work of the forces given in the possible movements of the system, corresponding to the displacement by the generalized coordinate $\delta\varphi_1$,

$$\delta A = \delta A(M_{\text{оe}}) + \delta A(G_1) + \delta A(G_2) + \delta A(G_3) + \delta A(F_x) + \delta A(F_y) + \delta A(F_{mp}) + \delta A(M_{mp}) \quad (9)$$

where $\delta A(M_{\text{оe}})$ - is the elementary work of the hydraulic motor, $\delta A(G_1)$ - the elementary work of the weight G_1 crank, $\delta A(G_2)$ - the elementary work of the weight G_2 of the connecting rod, $\delta A(G_3)$ - the elementary work of the weight G_3 slider, $\delta A(F_x)$ - the elementary work of the projection of the force of cutting on the X axis, $\delta A(F_y)$ - the elementary work of the projection of the force of cutting on the Y axis, $\delta A(F_{mp})$ - elementary work Friction forces in a pair of slider - guides, $\delta A(M_{mp})$ - elementary work of the forces of fluid friction in the hydraulic motor.

Dependence on the calculation of the elementary operation of the hydraulic motor has the form:

$$\delta A(M_{\text{оe}}) = q_1 \cdot (p_1 - p_2) \cdot \delta\varphi_1, \quad (10)$$

The essential work of the G_1 we calculate the crank by expression:

$$\delta A(G_1) = -G_1 \cdot \frac{O_1A}{2} \cdot \cos(\varphi_1) \cdot \delta\varphi_1, \quad (11)$$

An elementary work of the G_3 weight of the slider B is equal to zero:

$$\delta A(G_3) = 0, \quad (12)$$

To determine the elementary work of the weight G_2 of the connecting rod AB, which performs flat motion, we determine the position of its instantaneous velocity center O_2 as the point of intersection of the perpendiculars performed to the velocities of points A and B. We have:

$$\delta A(G_2) = -M_{O_2}(G_2) \cdot \delta\varphi_{O_2}, \quad (13)$$

The work is negative, since the direction of movement of the moment of weight G_2 relative to the axis O_2 and the instantaneous movement $\delta\varphi_{O_2}$ are the opposite. We find:

$$M_{O_2}(G_2) = G_2 \cdot \frac{AB}{2} \cdot \cos(\gamma), \quad (14)$$

Where the angle ABO_1 is denoted by γ .

To determine $\delta\varphi_{O_2}$, we use the possible movement δr_A of point A, which simultaneously belongs to the crank O_1A and the connecting rod AB. For a point A the crank has: $\delta r_A = O_1A \cdot \delta\varphi_1$. For point A, the connecting rod will be obtained $\delta r_A = AO_2 \cdot \delta\varphi_{O_2}$. Then $O_1A \cdot \delta\varphi_1 = AO_2 \cdot \delta\varphi_{O_2}$, from where:

$$\delta\varphi_{O_2} = \frac{O_1A}{AO_2} \cdot \delta\varphi_1. \quad (15)$$



To determine AO_2 , we draw an auxiliary horizontally through the point A. From the triangle AO_2E we obtain:

$$AO_2 = AB \cdot \frac{\cos(\gamma)}{\cos(\varphi_1)} \quad (16)$$

We substitute the received $M_{O_2}(G_2)$, $\delta\varphi_{O_2}$ and AO_2 in accordance with formulas (14), (15) and (16) in expression (13) and we obtain:

$$\delta A(G_2) = -G_2 \cdot \frac{AB}{2} \cdot \cos(\gamma) \cdot \frac{O_1A}{AB \cdot \cos(\gamma)} \cdot \delta\phi_1 = -G_2 \cdot \frac{O_1A}{2} \cdot \cos(\phi_1) \cdot \delta\phi_1 \quad (17)$$

The elementary work of the projection of the force of cutting on the X axis is calculated by expression:

$$\delta A(Q_x) = -Q_x \cdot \delta r_B, \quad (18)$$

where δr_B - the elementary movement of the slider.

The elementary movement of the slider should be expressed through the elementary angle of rotation of the shaft of the hydro-motor.

For an elementary displacement of point A, an expression is valid:

$$O_1A \cdot \delta\phi_1 = AO_2 \cdot \delta\varphi \quad (19)$$

The elementary displacement of point B is determined by expression:

$$\delta r_B = O_2B \cdot \delta\psi \quad (20)$$

Given the expression (19), the dependence (20) has the form:

$$\delta r_B = O_2B \cdot \frac{O_1A}{AO_2} \cdot \delta\phi_1 \quad (21)$$

According to Figure 5, the O_2B catenary of the triangle O_1O_2B can be calculated in terms of expression:

$$O_2B = AO_2 \cdot \sin(\phi_1) + AB \cdot \sin(\gamma) \quad (22)$$

To determine the angle γ , we construct an auxiliary vertex AD through point A.

From the triangles ADO_1 and ADO_2 we get:

$$\gamma = \arcsin\left(\frac{O_1A}{AB} \cdot \sin(\varphi_1)\right) \quad (23)$$

Taking into account the above expressions, we define the elementary movement of the slider, taking into account which we find the elementary work of the cutting power described has the form:

$$\delta A(Q_x) = -Q_x \cdot O_1A \cdot \frac{\sin\left(\arcsin\left(\frac{O_1A}{AB} \cdot \sin(\phi_1)\right) + \phi_1\right)}{\cos\left(\arcsin\left(\frac{O_1A}{AB} \cdot \sin(\phi_1)\right)\right)} \cdot \delta\phi_1 \quad (24)$$

The work of the frictional force in a pair of slider - the guide is calculated by the following expression:

$$\delta A(F_{mp}) = -f_{mp} \cdot Q_Y \cdot \delta r_B = -f_{mp} \cdot Q_Y \cdot O_1A \cdot \frac{\sin\left(\arcsin\left(\frac{O_1A}{AB} \cdot \sin(\phi_1)\right) + \phi_1\right)}{\cos\left(\arcsin\left(\frac{O_1A}{AB} \cdot \sin(\phi_1)\right)\right)} \cdot \delta\phi_1, \quad (25)$$

$$\delta A(M_{mp}) = -\beta_{mp} \cdot \frac{d}{dt} \phi_1 \cdot \delta\phi_1. \quad (26)$$

Consequently, the aggregated force is calculated by the following dependence:

$$Q_{\phi_1} = \frac{\delta A}{\delta\phi_1} = q_1 \cdot (p_1 - p_2) - G_1 \cdot \frac{O_1A}{2} \cdot \cos(\phi_1) - G_2 \cdot \frac{O_1A}{2} \cdot \cos(\phi_1) - Q_x \cdot O_1A \cdot \frac{\sin\left(\arcsin\left(\frac{O_1A}{AB} \cdot \sin(\phi_1)\right) + \phi_1\right)}{\cos\left(\arcsin\left(\frac{O_1A}{AB} \cdot \sin(\phi_1)\right)\right)} - f_{mp} \cdot Q_Y \cdot O_1A \cdot \frac{\sin\left(\arcsin\left(\frac{O_1A}{AB} \cdot \sin(\phi_1)\right) + \phi_1\right)}{\cos\left(\arcsin\left(\frac{O_1A}{AB} \cdot \sin(\phi_1)\right)\right)} - \beta_{mp} \cdot \frac{d}{dt} \phi_1 \quad (27)$$



The kinetic energy of the crank mechanism is calculated by the following dependence:

$$T = T_1 + T_2 + T_3, \quad (28)$$

Where T_1 - the kinetic energy of the crank, T_2 - the kinetic energy of the connecting rod, T_3 - the kinetic energy of the slider.

The crankshaft performs rotational motion, so the dependence for calculating kinetic energy has the form:

$$T_1 = \frac{1}{2} \cdot I_{O_1A} \cdot \left(\frac{d}{dt} \varphi_1 \right)^2, \quad (29)$$

Where I_{O_1A} - the moment of inertia of the crank, which is a homogeneous thin rod and is calculated by the following dependence:

$$I_{O_1A} = \frac{1}{3} \cdot m_{O_1A} \cdot O_1A^2, \quad (30)$$

Then expression (29) takes into account the expression (30):

$$T_1 = \frac{1}{6} \cdot m_{O_1A} \cdot O_1A^2 \cdot \left(\frac{d}{dt} \varphi_1 \right)^2 \quad (31)$$

The connecting rod performs a plane-parallel motion, hence the kinetic energy of the connecting rod, will be determined by the dependence:

$$T_2 = \frac{1}{2} \cdot I_{AB} \cdot \left(\frac{d}{dt} \varphi_{AB} \right)^2 + \frac{1}{2} \cdot m_{AB} \cdot V_C^2, \quad (32)$$

Where I_{AB} - the moment of inertia of the connecting rod AB, $\frac{d}{dt} \varphi_{AB}$ - the angular speed of rotation of the connecting rod AB around the instantaneous center of speed, m_{AB} - the weight of the connecting rod AB, V_C - the speed of the center of gravity of the connecting rod AB.

The moment of inertia of the connecting rod AB is calculated by dependence:

$$I_{AB} = \frac{1}{12} \cdot m_{AB} \cdot AB^2. \quad (33)$$

We find the dependence of the angular velocity of rotation of the rope around the instantaneous center of velocities and the linear velocity of moving the center of gravity of the rope from the generalized coordinate φ_1 .

As is known, the point A belongs simultaneously to the crank O_1A and the connecting rod AB, then the point speed can be calculated depending on:

$$V_A = O_1A \cdot \frac{d}{dt} \varphi_1 = AO_2 \cdot \frac{d}{dt} \varphi_{AB}, \quad (34)$$

$$\frac{d}{dt} \varphi_{AB} = \frac{O_1A}{AO_2} \cdot \frac{d}{dt} \varphi_1. \quad (35)$$

Given (20) and (21), the expression (32) will look like:

$$\frac{d}{dt} \varphi_{AB} = \frac{O_1A \cdot \cos(\varphi_1)}{AB \cdot \cos\left(\arcsin\left(\frac{O_1A}{AB} \cdot \sin(\varphi_1)\right)\right)} \cdot \frac{d}{dt} \varphi_1 \quad (36)$$

The square of the center of gravity of the crank AV will be calculated according to the dependence:

$$V_C^2 = \left(\frac{dX_C}{dt} \right)^2 + \left(\frac{dY_C}{dt} \right)^2, \quad (37)$$

Where X_C, Y_C - the coordinates of the center of gravity of the connecting rod AB.

$$X_C = O_1A \cdot \cos(\phi_1) + 0.5 \cdot AB \cdot \cos(\phi_2) = O_1A \cdot \cos(\phi_1) + 0.5 \cdot AB \cdot \cos\left(\arcsin\left(\frac{O_1A}{AB} \cdot \sin(\phi_1)\right)\right) \quad (38)$$

The center of gravity of the crank OA and the connecting rod AB are located in the middle and have the same ordinates:

$$Y_C = 0.5 \cdot O_1A \cdot \sin(\varphi_1). \quad (39)$$



Having differentiated expressions (38) and (39) in time and substituting expression (38), we obtain the following:

$$V_C^2 = \left(\left(\frac{-0.25 \cdot O_1 A^2 \cdot \sin(2 \cdot \phi_1)}{\sqrt{AB^2 - (O_1 A \cdot \sin(\phi_1))^2}} - O_1 A \cdot \sin(\phi_1) \right) \cdot \frac{d}{dt} \phi_1 \right)^2 + \left(0.5 \cdot AB \cdot \cos(\phi_1) \cdot \frac{d}{dt} \phi_1 \right)^2 \quad (40)$$

Then, taking into account the above dependence, the kinetic energy of the connecting rod will be determined by the expression:

$$T_2 = \frac{1}{24} \cdot m_{AB} \cdot \left(\frac{O_1 A \cdot \cos(\phi_1)}{\cos \left(\arcsin \left(\frac{O_1 A}{AB} \cdot \sin(\phi_1) \right) \right)} \cdot \frac{d}{dt} \phi_1 \right)^2 + \frac{1}{2} \cdot m_{AB} \cdot \left(\left(\frac{-0.25 \cdot O_1 A^2 \cdot \sin(2 \cdot \phi_1)}{\sqrt{AB^2 - (O_1 A \cdot \sin(\phi_1))^2}} - O_1 A \cdot \sin(\phi_1) \right) \cdot \frac{d}{dt} \phi_1 \right)^2 + \frac{1}{2} \cdot m_{AB} \cdot \left(0.5 \cdot AB \cdot \cos(\phi_1) \cdot \frac{d}{dt} \phi_1 \right)^2 \quad (41)$$

The kinetic energy of the slider is determined by the dependence:

$$T_3 = \frac{1}{2} \cdot m_B \cdot V_B^2 \quad (42)$$

Determine the linear velocity of the slider:

$$V_B = \frac{d}{dt} X_B = \left(\frac{-0.5 \cdot O_1 A^2 \cdot \sin(2 \cdot \phi_1)}{\sqrt{AB^2 - (O_1 A \cdot \sin(\phi_1))^2}} - O_1 A \cdot \sin(\phi_1) \right) \cdot \frac{d}{dt} \phi_1 \quad (43)$$

Substituting the expression (43) into (42), we obtain:

$$T_3 = \frac{1}{2} \cdot m_B \cdot \left(\left(\frac{-0.5 \cdot O_1 A^2 \cdot \sin(2 \cdot \phi_1)}{\sqrt{AB^2 - (O_1 A \cdot \sin(\phi_1))^2}} - O_1 A \cdot \sin(\phi_1) \right) \cdot \frac{d}{dt} \phi_1 \right)^2 \quad (44)$$

Consequently, the complete kinetic energy of the system is:

$$T = \frac{1}{6} \cdot m_{O_1 A} \cdot O_1 A^2 \cdot \left(\frac{d}{dt} \phi_1 \right)^2 + \frac{1}{24} \cdot m_{AB} \cdot \left(\frac{O_1 A \cdot \cos(\phi_1)}{\cos \left(\arcsin \left(\frac{O_1 A}{AB} \cdot \sin(\phi_1) \right) \right)} \cdot \frac{d}{dt} \phi_1 \right)^2 + \frac{1}{2} \cdot m_{AB} \cdot \left(\left(\frac{-0.25 \cdot O_1 A^2 \cdot \sin(2 \cdot \phi_1)}{\sqrt{AB^2 - (O_1 A \cdot \sin(\phi_1))^2}} - O_1 A \cdot \sin(\phi_1) \right) \cdot \frac{d}{dt} \phi_1 \right)^2 + \frac{1}{2} \cdot m_{AB} \cdot \left(0.5 \cdot AB \cdot \cos(\phi_1) \cdot \frac{d}{dt} \phi_1 \right)^2 + \frac{1}{2} \cdot m_B \cdot \left(\left(\frac{-0.5 \cdot O_1 A^2 \cdot \sin(2 \cdot \phi_1)}{\sqrt{AB^2 - (O_1 A \cdot \sin(\phi_1))^2}} - O_1 A \cdot \sin(\phi_1) \right) \cdot \frac{d}{dt} \phi_1 \right)^2 \quad (45)$$

Having carried out simple mathematical operations, we calculate a partial derivative of kinetic energy at generalized velocity and find a derivative of time from a partial derivative of kinetic energy in a generalized coordinate. We calculate the difference $\frac{d}{dt} \frac{\partial T}{\partial \omega_4} - \frac{\partial T}{\partial \omega_4}$ and give the Lagrange II equation to the

canonical form, grouping the resulting expression in order of the derivative and putting it in brackets:

$$I_{np} \cdot \frac{d^2}{dt^2} \phi_1(t) - \frac{1}{2} \cdot \frac{dI_{np}}{dt} \cdot \left(\frac{d}{dt} \phi_1(t) \right) = Q_{\phi_1} \quad (46)$$

Thus equations (1) - (46) describe the operation of a hydraulic drive system for knives of a segmental finger cutting device of a mower:

$$+K_1(p_1) \cdot W_1 \cdot \frac{d}{dt} p_1,$$



$$I_{np} \cdot \frac{d^2}{dt^2} \phi_1(t) - \frac{1}{2} \cdot \frac{dI_{np}}{dt} \cdot \left(\frac{d}{dt} \phi_1(t) \right) = Q_{\phi_1}$$

$$Q_{\phi_1} = \frac{\delta A}{\delta \phi_1} = q_1 \cdot (p_1 - p_2) - G_1 \cdot \frac{O_1 A}{2} \cdot \cos(\phi_1) - G_2 \cdot \frac{O_1 A}{2} \cdot \cos(\phi_1) - Q_x \cdot O_1 A \cdot \frac{\sin\left(\arcsin\left(\frac{O_1 A}{AB} \cdot \sin(\phi_1)\right) + \phi_1\right)}{\cos\left(\arcsin\left(\frac{O_1 A}{AB} \cdot \sin(\phi_1)\right)\right)}$$

$$- f_{mp} \cdot Q_y \cdot O_1 A \cdot \frac{\sin\left(\arcsin\left(\frac{O_1 A}{AB} \cdot \sin(\phi_1)\right) + \phi_1\right)}{\cos\left(\arcsin\left(\frac{O_1 A}{AB} \cdot \sin(\phi_1)\right)\right)} - \beta_{mp} \cdot \frac{d}{dt} \phi_1 \quad (47)$$

The research of the operation of this hydraulic mower system is carried out with the help of the software package MathCad. To calculate the transients that occur when the state of a given hydraulic system of the equation (1) - (47) is converted into a Cauchy form:

$$\frac{d}{dt} p_1 = \frac{(q_H \cdot n_H \cdot \eta_{o\delta} - q_M \cdot \omega_1 - \sigma_{sum1} \cdot p_1 - \sigma_{nep.1,2} \cdot (p_1 - p_2))}{K_1 \cdot W_1},$$

$$\frac{d}{dt} \omega_1 = \frac{q_{M4} \cdot (p_1 - p_2) + \frac{1}{2} \cdot \frac{dI_{np}}{dt} \cdot (\omega_1)^2}{I_{np}} - \frac{G_1 \cdot O_1 A}{I_{np} \cdot 2} \cdot \cos(\phi_1) - \frac{G_2 \cdot O_1 A}{I_{np} \cdot 2} \cdot \cos(\phi_1) -$$

$$\frac{f_{mp} \cdot Q_y \cdot O_1 A}{I_{np}} \cdot \frac{\sin\left(\arcsin\left(\frac{O_1 A}{AB} \cdot \sin(\phi_1)\right) + \phi_1\right)}{\cos\left(\arcsin\left(\frac{O_1 A}{AB} \cdot \sin(\phi_1)\right)\right)} - \beta_{mp} \cdot \omega_1,$$

$$\frac{d}{dt} \phi_1 = \omega_1. \quad (48)$$

To find solutions, we use the Runge-Kutta method with automatic change of the integration step.

Research of mathematical model of the advanced drive of knives of a mower with a hydraulic drive.

A characteristic feature of this mathematical model is the presence of a large number of nonlinear dependencies that describe the behavior of the elements of this hydro-system.

As a result of solving this system of equations using software, we obtain transitional processes for changing the pressure in the cavities of the hydro-system and the angular velocity of the hydro-motor shown in Figures 6 and 7 with the following parity of parameters: $q_4 = 20 \text{ cm}^3/\text{radian}$, $W_1 = 200 \text{ cm}^3$, $m_1 = 10 \text{ kg}$, $m_2 = 10 \text{ kg}$, $m_3 = 150 \text{ kg}$, $\beta_{mp4} = 1 \cdot 10^{-2} \text{ H} \cdot \text{M} \cdot \text{s}$, $Q_H = 1 \cdot 10^{-3} \text{ m}^3/\text{s}$, $O_1 A = 0.4 \text{ m}$, $AB = 0.6 \text{ m}$.

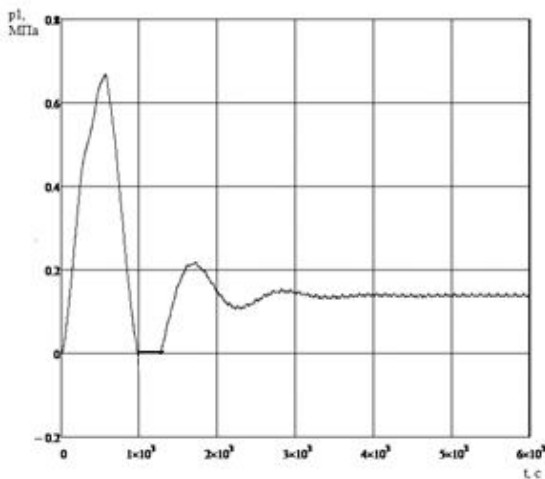

Fig. 6. The process of pressure change in the cavities of the hydrosystem

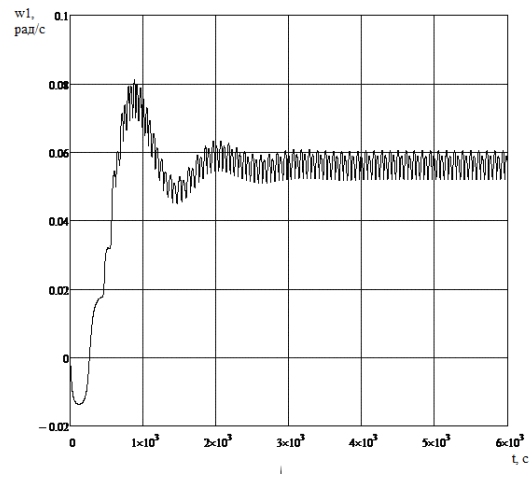

Fig. 7. The process of changing the angular velocity of the hydraulic motor



The transient processes shown in Figures 6 and 7 indicate that the system is operating in steady state, the fluctuations of pressure and velocity that arise at the time of start, fade within 2 - 2.5 s. Overregulation at speed does not exceed 30%, which indicates a low variability of the transition process. The adjustment time, which does not exceed 2.5 s, indicates a sufficiently high level of quality of the adjustment process. The obtained parameters of the transition process indicate that the hydro-system does not cause additional fluctuations in the design of the mower.

5. Conclusions

Based on the results of mathematical modeling can be concluded that this mathematical model adequately reflects the processes occurring in the drive blade mower with a hydraulic drive with loading of the working bodies and can be used for research to develop recommendations for designing and selecting the optimal parameters of this type.

References

- [1] Ukrayina mozhe pochati Importuvaty moloko [Elektronniy resurs] Elektronna statiya. – 25 grudnya 2015. – Rezhim dostupu: <http://agravery.com/uk/posts/show/ukraina-moze-pochati-importuvati-moloko>.
- [2] Bideev, S.I. Razrabotka i obosnovanie parametrov kosilki s beskonechnym nositelem rezhuschih elementov: avtoref. dis. na soiskanie nauch. stepeni kand. tekhn. nauk: 05.20.01 „Tekhnologii i sredstva mekhanizatsii selskogokhozyaystva” / I.S. Bideev– Vladikavkaz, 2010. – 14-21 s.
- [3] Gappoev, T.T. Nekotoryie voprosi uravnoveshivaniya rezhuschih apparatov s.h. uborochnykh mashin / T.T. Gappoev. D.B. Tabuev. Tez. dokl. Vsesoyuznoy nauchno-tekhnicheskoy konferentsii «Sovmestnie metody i sredstva uravnoveshivaniya mashin i priborov». – M. – Volgograd, 1979.
- [4] Gappoev, T.T. Uravnoveshivaniya vyisokoskorostnogo rezhuschego aparata uborochnoy mashiny / T.T. Gappoev. D.B. Tabuev. - Mekhanizatsiya i elektrifikatsiya selskogo hozyaystva. – M., 2001.
- [5] Sereda, L.P. Povyishenie effektivnosti protsessov uborki saharney sveklyi putem modernizatsii sveklouborochnykh mashin: avtoref. dis. na zdotuttya nauk. stupenya kand. tekhn. nauk: 05.05.11 „Mashiny i zasobi mekhanizatsiyi silskogospodarskogo virobnitstva” /L.P. Sereda. – Vinnitsya, 1985. – 56-62 s. 148 s.
- [6] Kravchuk, V., Metodika viznachennya perevitrat paliva pri zmini tekhnichnogo stanu gidroprivodiv silskogospodarskikh mashin / V. Kravchuk, V. Gorbatov / MOTROL. – 2009.- 11A, 138–145.
- [7] Ratushna, N., Metodichni pidhody do stvorenniya novoyi silskogospodarskoyi tekhniki u vidpovidnosti z vimogami rynku naukoemnoi produktsii / N. Ratushna, I. Mahmudov, A. Kokhno // MOTROL 2007. – № 9A, 119–123.
- [8] Istvan, Biro. Numerical investigation of kinematical functions of scythe driving mechanisms applied in agricultural mechanical engineering. ANNALS OF FACULTY ENGINEERING HUNEDOARA – International journal of engineering. Tome IX (Year 2011). Fascicule 3. (ISSN 1584-2673).
- [9] Ivanov, N. Matematicheskaia model gidroprivoda blochno-portsionoho otdelitelia konservirovannykh kormov / N. Ivanov, S. Sharhorodskiy, V. Rutkevych // MOTROL 2013. – Vol. 15. No 5. – 83–91.

ДОСЛІДЖЕННЯ МАТЕМАТИЧНОЇ МОДЕЛІ ГІДРОПРИВОДА СЕГМЕНТНО-ПАЛЬЦЕВОГО РІЗАЛЬНОГО АПАРАТА КОСАРКИ

Розглядається можливість заміни механічного привода сегментно-пальцевого різального апарата косарки простим гідроприводом, проведено моделювання динамічних процесів, які протікають в системі гідропривода сегментно-пальцевого різального апарата. Описано технологічний процес скошування з використанням гідропривода сегментно-пальцевого різального апарата. Наведено математичну модель гідропривода і результати її дослідження. На підставі отриманих результатів математичного моделювання зроблено висновок про те, що дана математична модель у достатній мірі відображає процеси, які відбуваються у гідроприводі ножів косарки при прикладанні навантаження до робочих органів і може бути використана для проведення досліджень з метою розроблення рекомендацій по конструюванню та вибору оптимальних параметрів систем даного типу.

Ключові слова: гідропривод, сегментно-пальцевий різальний апарат, косарка, скошування, робочий орган, динамічні навантаження, сили інерції.

Ф. 48. Рис. 7. Літ. 9.

**ИССЛЕДОВАНИЕ МАТЕМАТИЧЕСКОЙ МОДЕЛИ ГИДРОПРИВОДОВ СЕГМЕНТНО-ПАЛЬЦЕВОГО РЕЖУЩЕГО АППАРАТА КОСИЛКИ**

Рассматривается возможность замены механического привода сегментно-пальцевого режущего аппарата косилки простым гидроприводом, проведено моделирование динамических процессов, протекающих в системе гидропривода сегментно-пальцевого режущего аппарата. Описан технологический процесс скашивания с использованием гидропривода сегментно-пальцевого режущего аппарата. Приведена математическая модель гидропривода и результаты ее исследования. На основании полученных результатов математического моделирования сделан вывод о том, что данная математическая модель в достаточной мере отражает процессы, происходящие в гидроприводе ножей косилки при приложении нагрузки в рабочие органы и может быть использована для проведения исследований с целью разработки рекомендаций по конструированию и выбора оптимальных параметров систем данного типа.

Ключевые слова: гидропривод, сегментно-пальцевый режущий аппарат, косилка, скашивания, рабочий орган, динамические нагрузки, силы инерции.

Ф. 48. Рис. 7. Лит. 9.

ВІДОМОСТІ ПРО АВТОРІВ

Серета Леонід Павлович – кандидат технічних наук, професор кафедри «Експлуатації машинно-тракторного парку та технічного сервісу» Вінницького національного аграрного університету (вул. Сонячна, 3, м. Вінниця, 21008, Україна, e-mail: leonidsereda@vsau.vin.ua).

Руткевич Володимир Степанович – кандидат технічних наук, старший викладач кафедри «Машин та обладнання сільськогосподарського виробництва» Вінницького національного аграрного університету (вул. Сонячна, 3, м. Вінниця, 21008, Україна, e-mail: v_rut@ukr.net).

Зінєв Михайло Вікторович – асистент кафедри «Експлуатації машинно-тракторного парку та технічного сервісу» Вінницького національного аграрного університету (вул. Сонячна, 3, м. Вінниця, 21008, Україна, e-mail: misha1987@vsau.vin.ua).

Серета Леонид Павлович – кандидат технических наук, профессор кафедры «Эксплуатации машинно-тракторного парка и технического сервиса» Винницкого национального аграрного университета (ул. Солнечная, 3, г. Винница, 21008, Украина, e-mail: leonidsereda@vsau.vin.ua).

Руткевич Владимир Степанович – кандидат технических наук, старший преподаватель кафедры «Машин и оборудования сельскохозяйственного производства» Винницкого национального аграрного университета (ул. Солнечная, 3, г. Винница, 21008, Украина, e-mail: v_rut@ukr.net).

Зинев Михаил Викторович – ассистент кафедры «Эксплуатации машинно-тракторного парка и технического сервиса» Винницкого национального аграрного университета (ул. Солнечная, 3, г. Винница, 21008, Украина, e-mail: misha1987@vsau.vin.ua).

Sereda Leonid – PhD, Full Professor of the department of "Operation of machine-tractor park and technical service" of Vinnytsia National Agrarian University (3, Solnyshchaya St., Vinnytsia, 21008, Ukraine, e-mail: leonidsereda@vsau.vin.ua).

Rutkevych Volodymyr – PhD, senior lecturer of the department "Machines and equipment for agricultural production" of the Vinnytsia National Agrarian University (3, Solnyshchaya St., Vinnytsia, 21008, Ukraine, e-mail: v_rut@ukr.net).

Ziniev Mikhail – assistant of the department "Operation of a machine-tractor park and technical service" of Vinnytsia National Agrarian University (3, Solnyshchaya St., Vinnytsia, 21008, Ukraine, e-mail: misha1987@vsau.vin.ua).