

Oleg Sergiyenko · Wendy Flores-Fuentes · Paolo Mercorelli *Editors*

Machine Vision and Navigation

This book presents a variety of perspectives on vision-based applications. These contributions are focused on optoelectronic sensors, 3D & 2D machine vision technologies, robot navigation, control schemes, motion controllers, intelligent algorithms and vision systems. The authors focus on applications of unmanned aerial vehicles, autonomous and mobile robots, industrial inspection applications and structural health monitoring. Recent advanced research in measurement and others areas where 3D & 2D machine vision and machine control play an important role, as well as surveys and reviews about vision-based applications. These topics are of interest to readers from diverse areas, including electrical, electronics and computer engineering, technologists, students and non-specialist readers.

- Presents current research in image and signal sensors, methods, and 3D & 2D technologies in vision-based theories and applications;
- Discusses applications such as daily use devices including robotics, detection, tracking and stereoscopic vision systems, pose estimation, avoidance of objects, control and data exchange for navigation, and aerial imagery processing;
- Includes research contributions in scientific, industrial, and civil applications.

ISBN 978-3-030-22586-5



9 783030 225865

► springer.com

Sergiyenko · Flores-Fuentes
Mercorelli *Eds.*

1

Machine Vision and Navigation

Oleg Sergiyenko · Wendy Flores-Fuentes · Paolo Mercorelli *Editors*

Machine Vision and Navigation

 Springer

Oleg Sergiyenko
Wendy Flores-Fuentes
Paolo Mercorelli *Editors*

Machine Vision and Navigation

 Springer

Machine Vision and Navigation

Oleg Sergiyenko • Wendy Flores-Fuentes
Paolo Mercorelli
Editors

Machine Vision and Navigation

Springer

Editors

Oleg Sergiyenko
Universidad Autónoma de Baja California
Mexicali
Baja California, Mexico

Wendy Flores-Fuentes
Universidad Autónoma de Baja California
Mexicali
Baja California, Mexico

Paolo Mercorelli
Leuphana University of Lueneburg
Lueneburg, Low Saxony
Niedersachsen, Germany

ISBN 978-3-030-22586-5 ISBN 978-3-030-22587-2 (eBook)
<https://doi.org/10.1007/978-3-030-22587-2>

© Springer Nature Switzerland AG 2020

This work is subject to copyright. All rights are reserved by the Publisher, whether the whole or part of the material is concerned, specifically the rights of translation, reprinting, reuse of illustrations, recitation, broadcasting, reproduction on microfilms or in any other physical way, and transmission or information storage and retrieval, electronic adaptation, computer software, or by similar or dissimilar methodology now known or hereafter developed.

The use of general descriptive names, registered names, trademarks, service marks, etc. in this publication does not imply, even in the absence of a specific statement, that such names are exempt from the relevant protective laws and regulations and therefore free for general use.

The publisher, the authors, and the editors are safe to assume that the advice and information in this book are believed to be true and accurate at the date of publication. Neither the publisher nor the authors or the editors give a warranty, express or implied, with respect to the material contained herein or for any errors or omissions that may have been made. The publisher remains neutral with regard to jurisdictional claims in published maps and institutional affiliations.

This Springer imprint is published by the registered company Springer Nature Switzerland AG.
The registered company address is: Gewerbestrasse 11, 6330 Cham, Switzerland

Preface

Machine vision to provide spatial coordinate's measurement has developed in a wide range of technologies for multiple fields of applications such as robot navigation, medical scanning, and structural health monitoring, to mention some. Machine vision methods also have applications in search, classification, industrial process robotics (monitoring tools capable of visualizing various phenomena that occur during industrial process), rescue, vigilance, mapping, dangerous objects/subjects detection, and other areas where machine control based on vision plays an important role. The computer vision has guided the machine vision to the tendency of duplicating the abilities of human vision by electronically perceiving and understanding an image for high-dimensional data and optimizing the data storage requirement and the time processing due to the complexity of algorithms to extract important patterns and trends to understand what data says.

Autonomous mobile robots are every day more common; they can be commercially available dotted with machine vision capabilities for diverse tasks and applications, like surveillance, 3D model reconstruction, localization and mapping based on stereo vision, cleaning, medical assistance, and assist handicapped and elderly people. All these robots missions require to the ability to work interactively in human environments and with online learning. Mobile robots with machine vision can be set up to detect, track, and avoid obstacles for optimal navigation. They can also estimate its pose and construct a 3D structure of a scene. Their vision can be based on stand-alone sensors or cameras based on sensors, filters, lens, and electronic and mechanical focus. Everyday cameras are more considered in research projects because they are affordable, inexpensive, robust, and compact. They capture a large amount of data reflecting both the photometric and geometric properties of the observed scene; however, they require considerable computing power and have a number of limitations related to the used sensors and their whole optical path design.

In this sense, *Machine Vision and Navigation* is important to modern science and industrial practical implementation. Hence, it is necessary to create new algorithms and systems to improve their performance. Although machine vision, control systems, and navigation applications for research and industrial areas are the primary interest in exploration, contaminated areas after natural and man-made

disasters on our planet, as well as of unknown terrains on other planets, are also important, and the conjunctive use of these technologies and automatic systems is desirable.

The chapters in this book relate to contributions in machine vision applications. Each book chapter shows the state of the art in stand-alone sensors, cameras, methods, and 3D and 2D technologies in machine vision as well as the novel strategies in navigation performance.

These contributions are focused on optoelectronic sensors, 3D and 2D machine vision technologies, robot navigation, control schemes, motion controllers, intelligent algorithms, and vision systems, particularly on applications of unmanned aerial vehicle, autonomous and mobile robots, industrial inspection applications, and structural health monitoring. Recent advanced research in measurement and other areas where 3D and 2D machine vision and machine control play an important role as well as significant surveys and reviews about machine vision applications.

This book covers both theories and application of machine vision and navigation topics. In our opinion, this book should be attractive for potential consumers/citizens because in our vision it is a well-balanced source of novel technologies in the area of machine vision and navigation with an explicit overview of recently existing systems, giving the comparative analysis of its features, advantages, and disadvantages. The topics are of interest to readers from a diverse audience in different areas of specialty as electrical, electronics, and computer engineering, technologists, and nonspecialist readers. The book is intended to be used as a text and reference work on advanced topics in machine vision and navigation. It is dedicated to academics, researchers, advanced-level students, and technology developers who will find this text useful in furthering their research exposure to pertinent topics in *Machine Vision and Navigation* and assisting in their future own research efforts in this field.

An Overview of Machine Vision and Navigation

The combination of machine vision and navigation is most promising nowadays, in recent years, we are finally seeing the full-scale release of daily-use devices, such as IObot cleaners, IObot assistants for the elderly, and so on. From previous experience, this is the best marker of the upcoming boom of demand of novel competitive technologies in the field. Covering all the topics of study in this book would be impossible; however, the most significant have been selected. The book contains 26 chapters which have been classified into five parts: (1) Image and Signal Sensors; (2) Detection, Tracking, and Stereoscopic Vision Systems; (3) Pose Estimation, Avoidance of Objects, Control, and Data Exchange for Navigation; (4) Aerial Imagery Processing; and (5) Machine Vision for Scientific, Industrial, and Civil Applications. These are briefly described in the following.

Chapter 1 is dedicated to image sensors and signal sensors used in current machine vision systems. Some of them suffer from low dynamic range and poor color constancy and are brittle and unmalleable, limiting their use in applications for which

there will be considerable demand in the future. Most approaches aiming to resolve these inadequacies focus on developing improvements in the lighting, and software (processing algorithms) or hardware surrounding the photosensor such as filters is presented. Also discussed are other strategies that involve changing the architecture of the image sensor and the photo-sensing material; both have experienced recent success. Although they are yet to break fully into the market, image sensors developed from alternative solution-processed materials such as organic semiconductors and organohalide perovskites have immense potential to address the above issues and to "disrupt" machine vision technology.

Chapter 2 proposes a novel passive vision sensor with a 360° horizontal field of view for mobile robots. With the implementation of this sensor, the robots can be provided with the ability of rapid detection of objects with a peripheral and central vision. The development of this sensor has been inspired by the peripheral/foveal typical vision in cooperation with the visual perception of vertebrates. It is based on the exploit of a catadioptric camera, while a rotating perspective camera makes it possible to measure distances, focusing attention on an already detected object, with a simple calibration methodology of the hybrid field-of-view vision systems. The sensor has been set up as a stand-alone and real-time sensor. It is a self-contained unit hosted in a single-board embedded computer with parallel processing capabilities that can be installed on any mobile robot, even those that have very limited computing power.

Chapter 3 focuses on the color and depth sensing technologies and analyzes how they play an important role in localization and navigation in unstructured environments. It discusses the important role of scanning technologies in the development of trusted autonomous systems for robotic and machine vision with an outlook for areas that need further research and development. A review of sensor technologies for specific environments is included, with special focus on the selection of a particular scanning technology to deal with constrained (indoor) or unconstrained (outdoor) environments. Fundamentals, advantages, and limitations of color and depth (RGB-D) technologies such as stereo vision, time of flight, and structured light and shape from shadow are discussed in detail. Strategies to deal with lighting, color constancy, occlusions, scattering, haze, and multiple reflections are evaluated in detail. It also introduces the latest developments in this area by discussing the potential of emerging technologies, such as dynamic vision and focus-induced photoluminescence.

Chapter 4 is a work developed for the construction of mixed image processor (IP) and neural networks (NNs) and image intensity transformation and the fundamentals of continuous logic cell (CLC) design based on current mirrors (CM) with functions of preliminary analog processing. The intention of the authors is to create video sensors and processors for parallel (simultaneous by pixel) image processing with advanced functionality and multichannel picture outputs to work in particular in hardware with high-performance architectures of neural networks, convolutional neural structures, parallel matrix-matrix multipliers, and special-processor systems. The theoretical foundations are analyzed. The mathematical apparatus of the matrix and continuous logic, their basic operations, and their functional completeness are

described. The evaluation of their advantages and prospects for application in the design of Biologically inspired devices and systems for processing and analysis of array signals are presented. It is demonstrated that some functions of continuous logic, including operations of normalized equivalence of vector and matrix signals, and the operation of a limited difference in continuous logic are a powerful basis for designing improved smart micro-cells for analog transformations and analog-digital encodings.

Chapter 5 proposes the use of a robotic total station assisted with cameras for detection and tracking of targets that are not signalized by reflectors. It introduces the principles of standard total stations, defining them as "modern geodetic multi-sensor systems measuring horizontal and vertical angles as well as distances using time-of-flight methods, thus delivering 3D-coordinates for static as well as moving objects." However, it focuses on the equipment of these systems with cameras and the application of photogrammetric techniques for the development of robotic image-assisted total stations for static and kinematic objects. Some examples of applications are described and a quality control study result is presented.

Chapter 6 offers a clear presentation of the methods and mathematical models for coordinate estimation using radar technologies and problems related to the recognition of object characteristics (landmarks) for mobile autonomous robots. Basically, it is devoted to the actual problem of navigating mobile autonomous robots on unknown terrains in the absence of GPS. Such a problem is considered solved if the robot is capable to detect a landmark and estimate own coordinates relative to the landmark. A reliable method for solving the problem is the simultaneous use of several measuring systems operating on different physical principles. In classical radar, the reliable detection of the echo signals from immovable landmark, which differ little from the echo signals that are reflected from the surrounding area, is impossible. Comparison of such signals is carried out in the chapter for various terrains at different lengths of electromagnetic waves. It is found that the only difference between them is the possible amplitude jump of signal, reflected from the landmark. This jump occurs during the movement of the robot or scanning the space by the robot antenna. The probability of detecting such a jump, the accuracy of the amplitude estimation, and the speed of the device operation are analyzed in the chapter based on the developed system of stochastic differential equations.

Chapter 7 overviews different machine vision systems in agricultural applications. Several different applications are presented but a machine vision system which estimates fruit yield, an example of an orchard management application, is discussed at length. From the farmer's perspective, an early yield prediction serves as an early revenue estimate. From this prediction, resources, such as employees and storage space, can more efficiently be allocated, and future seasons can be better planned. The yield estimate is accomplished using a camera with a color filter that isolates the blossoms on a tree when the tree is in its full blossom. The blossoms in the resulting image can be counted and the yield estimated. An estimate during the blossom period, as compared to when the fruit has begun to mature, provides a crop yield prediction several months in advance. Discussed as well, in this chapter, is a machine vision system which navigates a robot through orchard rows. This system

can be used in conjunction with the yield estimation system, but it has additional applications such as incorporating a water or pesticide system, which can treat the trees as it passes by. To be effective, this type of system must consider the operating scene as it can limit or constrain the system effectiveness. Such systems tend to be unique to the operating environment.

Chapter 8 presents a deep review of stereoscopic vision systems (SVS), and their description, classification (geometric configuration, quantity of cameras, and other characteristics related with mathematical and computer processing), advantages, disadvantages, and applications in the current state of the art are stated. It is also noted that geometries of the SVS's shown in this chapter are ideal and are not considered factors that could affect the accuracy of measurements. The aim of the chapter is to provide information for everyone who wants to implement an SVS and needs an introduction to several available options to use the most convenient according to a specific application.

Chapter 9 is focused on the development of machine vision for robots, robot pose estimation, and 3D reconstruction of scenes through a set of matched correspondences and features extracted from multiple images. It provides modern and advanced strategies for image filtering and image feature extraction. It concentrates on stereo vision noise source that results in a 3D reconstruction of a scene. Strategies for image filtering and feature extraction are described based on techniques, such as Kalman Filter (KF), extended Kalman filter (EKF), and unscented Kalman filter (UKF). These filters are presented in order to increase the efficiency of visual simultaneous localization and mapping (VSLAM) algorithm to increase its efficiency. Practical examples in the field of robotics vision research are described, like pose tracking using UKF and stereo vision and localization approach-based 2D-landmarks map.

Chapter 10 is dedicated to the development of mathematical fundamentals for pose estimation. Pose estimation requires optimally estimating translation and rotation. The chapter is focused on rotation, since it involves nonlinear analysis. It is demonstrated how the computation can be done systematically if it is exploited the fact that the set of rotations forms a group of transformations, called the "special orthogonal group." A linear space spanned by infinitesimal rotations called the "Lie algebra" is defined. A computational procedure for minimizing the optimization function of a rotation based on Lie algebra formulation is described and applied to three computer vision problems: (1) Given two sets of 3D points, it is optimally estimated the translation and rotation between them in the presence of inhomogeneous anisotropic noise. (2) Given corresponding points between two images, it is optimally computed the fundamental matrix. (3) It is described the procedure of bundle adjustment for computing, from images of multiple points in the scene taken by multiple cameras, the 3D locations of all the points, and the postures of all the cameras as well as their internal parameters.

Chapter 11 shows a methodology for the accurate generation and tracking of closed trajectories over arbitrary, large surfaces of unknown geometry, using a robot whose control is based on the use of a non-calibrated vision system. The proposed technique referred to as camera-space manipulation is combined with a geodesic-mapping approach, with the purpose of generating and tracking a trajectory studied as

a CAD model, over an arbitrarily curved surface, along with a user-defined position and orientation. A measure used to diminish the distortion caused by the mapping procedure and a technique for achieving closure of a given closed path, when this is tracked over large, non-developable surfaces, are presented herein. The performance of the proposed methodology was evaluated using an industrial robot with a large workspace whose geometry is not known in advance, combined with structured lighting used to reduce the complexity of the image analysis process.

Chapter 12 deals with generic image-based visual servoing control structure with onboard camera, based on the passivity theory and application. It gives a mathematical approach and a detailed literature research including also contributions of recent publications. The authors prove the convergence to zero of the control error and its robustness in the context of L_2 -gain performance. A unified passivity-based visual servoing control structure considering a vision system mounted on the robot is presented. This controller is suitable to be applied for robotic arms, mobile robots, as well as mobile manipulators. The proposed control law makes the robot able to perform a moving target tracking in its workspace. Taking advantage of the passivity properties of the control system and considering exact knowledge of the target's velocity, the asymptotic convergence to zero of the control errors is proved. Later, it is carried a robustness analysis out based on L_2 -gain performance, hence proving that control errors are ultimately bounded even when there exist bounded errors in the estimation of the target velocity. Both numerical simulation and experimental results illustrate the performance of the algorithm in a robotic manipulator, in a mobile robot, and also in a mobile manipulator.

Chapter 13 is about data exchange and task of navigation for robotic group. Robotic group collaboration in a densely cluttered terrain is one of the main problems in mobile robotics control. The chapter describes the basic set of tasks solved in model of robotic group behavior during the distributed search of an object (goal) with the parallel mapping. Navigation scheme uses the benefits of authors' original technical vision system (TVS) based on dynamic triangulation principles. According to the TVS output data were implemented fuzzy logic rules of resolution stabilization for improving the data exchange. The dynamic communication network model was modified and implemented the propagation of information with a feedback method for data exchange inside the robotic group. For forming the continuous and energy-saving trajectory, the authors are proposing to use two-step post-processing method of path planning with polygon approximation. Combination of our collective TVS scans fusion and modified dynamic data exchange network forming method with dovetailing of the known path planning methods can improve the robotic motion planning and navigation in unknown cluttered terrain.

Chapter 14 proposes a hierarchical navigation system combining the benefits of perception space local planning and allocentric global planning. Perception space permits computationally efficient 3D collision checking, enabling safe navigation in environments that do not meet the conditions assumed by traditional navigation systems based on planar laser scans. Contributions include approaches for scoring and collision checking trajectories in perception space. Benchmarking results show the advantages of perception space collision checking over popular alternatives

in the context of real-time local planning. Simulated experiments with multiple robotic platforms in several environments demonstrate the importance of 3D collision checking and the utility of a mixed representation hierarchical navigation system.

Chapter 15 corresponds to a deep overview regarding autonomous mobile vehicles for wheeled ground applications. The different autonomy levels of vehicles are approached. The main concepts from path planning, going through the basic components that an autonomous vehicle must have, all the way to the perception it has of its environment, including the identification of obstacles, signs, and routes, are presented. The most commonly used hardware for the development of these vehicles is discussed. In the last part of this chapter, a case study, "Intelligent Transportation Scheme for Autonomous Vehicles in Smart Campuses," is incorporated in order to help illustrate the goal of the chapter. Finally, an insight is included on how the innovation on business models can and will change the future of vehicles.

Chapter 16 is devoted to the approach of passive combined correlation-extreme systems implementing the survey-comparative method for recognition and analysis of images obtained from the machine vision system of a flying robot, which is able to significantly improve the correct localization of the objects in the image frame. A basic model for the radiometric channel operation of the correlation-extreme navigation systems is proposed. The factors that lead to distortions of the decisive function formed by the combined correlation-extreme navigation system of flying robots in a developed infrastructure are allocated. A solution of the problem of autonomous low-flying flying robots navigation in a developed infrastructure using the radiometric channel extreme correlation navigation systems (CENS), when the size of the solid angle of associated object is much larger than the size of the partial antenna directivity diagram (ADD), is proposed.

Chapter 17 is focused in the description of an analytic image stabilization approach where pixel information from the focal plane of the camera is stabilized and georegistered in a global reference frame. The aerial video is stabilized to maintain a fixed relative displacement between the moving platform and the scene. The development of the algorithm that is able to stabilize aerial images using its available weak/noisy GPS and IMU measurements, based on the use of analytically defined homographies between images and minimizing the cost function on a 2D equation space, is presented. The algorithm is applied in the Defense Advanced Research Projects Agency (DARPA) video and image retrieval and analysis tool (VIRAT) data set and wide area motion images (WAMI).

Chapter 18 describes a visual servo controller designed for an unmanned aerial vehicle dedicated to tracking vegetable paths. In the inspection and data collection of large areas as crop fields, where an aerial vehicle should follow an object's line accurately, autonomous flight is a desirable feature with unmanned aerial vehicles. To attain this objective, three visual servo controllers are proposed; one of them is position based and the other two are image based using inverse Jacobian and concepts of passivity, respectively. All controllers are developed based on the kinematic model of the vehicle, and a dynamic compensation is designed to be added in cascade with the kinematic one. The performance of the control systems is compared through simulation results. The main contribution is the development of the image-

based controller using passivity properties of the system, the stability and robustness analysis, and the comparative performance with other controllers when used for an unmanned aerial vehicle following vegetal lines. These comparative results are valuable to choose the appropriate driver for a specific application.

Chapter 19 is the result of a deep study and research of multimedia compression advances, focusing on the use of the integer discrete cosine transform, the wavelet transform, and fovea centralis. Data compression is concerned with minimization of the number of information-carrying units used to represent a given data set. Such smaller representation can be achieved by applying coding algorithms. Coding algorithms can be either lossless algorithms that reconstruct the original data set perfectly or lossy algorithms that reconstruct a close representation of the original data set. Both methods can be used together to achieve higher compression ratios. Lossless compression methods can either exploit statistical structure of the data or compress the data by building a dictionary that uses fewer symbols for each string that appears on the data set. Lossy compression on the other hand uses a mathematical transform that projects the current data set onto the frequency domain. The coefficients obtained from the transform are quantized and stored. The quantized coefficients require less space to be stored.

Chapter 20 shows a method to solve the stairway localization and recognition problem for both indoor and outdoor cases by using a convolutional neural network technique. This work has been motivated because for blind and visually impaired persons, this assistive technology application has an important impact in their daily life. The proposed algorithm should be able to solve the problem of stair classification for indoor and outdoor scenes. The proposed idea describes the strategy for introducing an affordable method that can recognize stairways without taking into account the environments. Firstly, this method uses stair features to classify images by using convolutional neural networks. Secondly, stairway candidate is extracted by using the Gabor filter, a linear filter. Thirdly, the set of lines belonging to the ground plane are removed by using the behavioral distance measurement between two consecutive frames. Finally, it is extracted from this step the tread depth and the riser height of the stairways.

Chapter 21 gives a deep review of new- and advanced-phase triangulation methods for 3D-shape measurements in scientific and industrial applications. The mathematical methods for phase triangulation are presented, which allow the measurement of 3D data under the conditions of arbitrary light-scattering properties of the scanning surface, varying measurement setting external illumination and limited depth of field of optical elements of the source and receiver of optical radiation. The book chapter provides a deep mathematical approach about the proposed steady-state method for decoding phase images and presents a method for nonlinearity compensation of the source-receiver path of optical radiation in 3D measurements. The application of the proposed methods provides higher metrological characteristics of measuring systems and expands the functionality and the range of application of optical-electronic systems for geometric control in the production environment.

Chapter 22 presents a thermal image processing method to monitor a moving melt pool of a blown powder deposition process using infra-red thermography. Thereby, the moving melt pool is created on a substrate material by the use of a laser and a motorized work table, where the material is (stainless steel 316) deposited in a layer-by-layer sequence on the substrate material. The steel is placed in powder form on the substrate and brought to its melting point by means of a 1 kW fiber laser with a wavelength of 1064 nm. By controlling a fixed melting pot size in closed-loop configuration, a consistent material deposition and layer thickness of the deposited material are ensured. For the feedback of the closed-loop control, an energy management system and a height control system are used to track the total spectral radiance of the melt pool and to track the top of the deposited material. The chapter gives a good and practical overview of the blown powder deposition process using infra-red thermography and names the used technologies to implement the melting and tracking process. It uses Planck's law to define the spectral radiance of the melt pool for the energy management system. It also presents infrared thermographs to detect different temperature regions of the melt pool.

Chapter 23 describes the importance of image processing of measurement signals that are contaminated with noise for accurate fault detection and isolation in machines. This chapter presents processing filters to detect step changes in noisy diagnostic signals of a gas turbine, which the authors use as indicators for a subset of a single fault of these signals. By using the process filters, the noise of the gas turbine diagnostic signals is reduced and the examined for a step change. Various linear and nonlinear process filters are described and compared, where the weighted recursive median (WRM) filter is highlighted for good noise reduction. Also, the ant colony optimization (ACO) method is used to calculate the integer weights of the weighted recursive median filter.

Chapter 24 proposes a new method to control and automatize the position of three-axis piezoelectric nano-manipulators that handle a GSG nanoprobe to ensure the precise positioning of the probe on the substrate under test. The method is based on a measurement setup that consists of a vector network analyzer (VNA) connected through coaxial cables to miniaturized homemade coplanar waveguide (CPW) probes (one signal contact and two ground contacts), which are themselves mounted on three-axis piezoelectric nano-manipulators SmartAct™. The device under test (DUT) is positioned on a sample holder equipped also with nano-positioners and a rotation system with μ -degree resolution. The visualization is carried out by a scanning electron microscope (SEM) instead of conventional optics commonly found in usual on-wafer probe stations. This study addresses the challenge related to the control of nano-manipulators in order to ensure precisely the contact between the probe tips and the DUT to be characterized.

Chapter 25 shows the design of an industrial inspection system for plastic parts. The development of user-friendly design and training tool for convolutional neural networks (CNNs) and support vector machines (SVMs) as an application development environment based on MATLAB is presented. As the first test trial, an application of deep CNN (DCNN) for anomaly detection is developed and trained using a large number of images to distinguish undesirable small defects such as crack,

burr, protrusion, chipping, spot, and fracture phenomena that occur in the production process of resin molded articles. Then, as the second test trial, a SVM incorporated with the AlexNet and another SVM incorporated with our original sssNet are, respectively, designed and trained to classify sample images into accepting as OK or rejecting as NG categories with high categorization rate. In the case of these SVMs, the training can be conducted by using only images of OK category. The AlexNet and the sssNet are different types of DCNNs, whose compressed feature vectors have 4096 and 32 elements, respectively. The two lengths of compressed feature vectors are used as the inputs for the two types of SVMs, respectively. The usability and operability of the developed design and training tool for DCNNs and SVMs are demonstrated and evaluated through training and classification experiments.

Chapter 26 is dedicated to a structural health monitoring application. It describes that due to the increase of frequency and weight of commercial ship trips in waterways, bridges are more vulnerable than ever to ship-bridge collision accidents. It explains that there are plenty of reports of such cases all over the world, leading to millions of economic losses. For ancient bridges, irreparable damage might come in the sense of cultural value except for economic losses. The development of computer vision-based technology provides an active defense method to prevent the damage in advance. This chapter presents a computer vision-based method for ship-bridge collision assessment and warning for an ancient mch bridge over the Beijing-Hangzhou Grand Canal in Hangzhou, China. The structural characteristic and current status of the mch bridge were analyzed. The traffic volume and parameters of passing ships including velocity and weight were investigated. Water area in both sides of the bridge was divided into three different security districts corresponding to different warning levels. Image processing techniques were exploited to identify the types of ships for tracking. The potential of ship-bridge collision was assessed, and warning was generated according to the security evaluation.

Mexicali, Mexico
Mexicali, Mexico
Lueneburg, Germany

Oleg Sergiyenko
Wendy Flores-Fuentes
Paolo Mercorelli

Acknowledgment

It is a pleasure to offer our acknowledgment to all the *authors* that have contributed with a chapter in this book *Machine Vision and Navigation*. Every author has given their best effort in writing his most recent research findings. We feel satisfied with the academic product generated with an international vision. One hundred researchers around the world have collaborated in this project, representing the participation of 19 countries: Argentina, Australia, Canada, China, Ecuador, Egypt, France, Germany, India, Japan, Mexico, Panama, Poland, Russia, South Korea, Spain, Syria, Ukraine, and the USA. A whole list of the authors with the affiliations and biographies is provided in the "Contributors" and "About the Authors" sections of this book.

We are delighted and thankful to have received the support of researchers in the areas of machine vision, navigation, robotics, control, and artificial intelligences. We extend our acknowledgment to all the *reviewers* who have done a great job reading and suggesting improvements for each chapter: Alexander Gurko, Daniel Hernández-Balbuena, Danilo Caceres-Hernandez, Fabian N. Murrieta-Rico, Julio C. Rodriguez-Quirion, Lars Lindner, Moises Rivas-López, Moises J. Castillo-Toscano, Vera Tyrsa, and Wilmar Hernandez Perdomo.

Acknowledgments go also to the editorial board and the officials at Springer International AG for their invaluable efforts, great support, and valuable advice for this project toward the successful publication of this book. We also want to thank our institutions Universidad Autónoma de Baja California and Leuphana University of Lueneburg that provided us with a location and time where to develop this project.

Baja California, Mexico
Lueneburg, Germany
Baja California, Mexico

Oleg Sergiyenko
Paolo Mercorelli
Wendy Flores-Fuentes

Contents

Part I Image and Signal Sensors

1	Image and Signal Sensors for Computing and Machine Vision: Developments to Meet Future Needs	3
	Ross D. Jansen-van Vuuren, Ali Shahnewaz, and Ajay K. Pandey	
2	Bio-Inspired, Real-Time Passive Vision for Mobile Robots	33
	Piotr Skrzypczynski, Marta Rostkowska, and Maiek W sik	
3	Color and Depth Sensing Sensor Technologies for Robotics and Machine Vision	59
	Ali Shahnewaz and Ajay K. Pandey	
4	Design and Simulation of Array Cells of Mixed Sensor Processors for Intensity Transformation and Analog-Digital Coding in Machine Vision	87
	VladimiI G. Kiasilenko, Alexandel A. Lazarev, and Diana V. Nikitovich	

Part II Detection, Tracking and Stereoscopic Vision Systems

5	Image-Based Target Detection and Tracking Using Image-Assisted Robotic Total Stations	133
	Volker Schwieger, Gabriel Kerekes, and Otto Leike	
6	The Methods of Radar Detection of Landmarks by Mobile Autonomous Robots	171
	Oleksandr Poliarus and Yevhen Poliakov	
7	Machine Vision System for Orchard Management	197
	Duke M. Bulanon, TyleI Hestand, ConnoI Nogales, Brice Allen, and Jason Colwell	

8 Stereoscopic Vision Systems in Machine Vision, Models, and Applications	241
Luis Roberto Ramirez-Hernandez, Julio Cesar Rodriguez-Quirion, Moises J. Castro-Toscano, Daniel Hernandez-Balbuena, Wendy Flores-Fuentes, Moises Rivas-Lopez, Lars Lindner, Danilo Caceres-Hernandez, Marina Kolendovska, and Fabian N. Murrieta-Rico	
9 UKF-Based Image Filtering and 3D Reconstruction	267
Abdulkader Joukhadar, Dalia Kass Hanna, and Etezaz Abo Al-Izam	
Part 111 Pose Estimation, Avoidance of Objects, Control and Data Exchange for Navigation	
10 Lie Algebra Method for Pose Optimization Computation	293
Kenichi Kanatani	
11 Optimal Generation of Closed Trajectories over Large, Arbitrary Surfaces Based on Non-calibrated Vision.....	321
Emilio J. Gonzalez-Galvan, Ambrocio Loredon-Flores, Isela Bonilla-Gutierrez, Marco O. Mendoza-Gutierrez, Cesar Chavez-Olivares, Luis A. Raygoza, and Sergio Rolando Cruz-Ramirez	
12 Unified Passivity-Based Visual Control for Moving Object Tracking	347
Flavio Roberti, Juan Marcos Toibey, Jorge A. Sarapura, Victor Andaluz, Ricardo Carelli, and Jose Maria Sebastian	
13 Data Exchange and Task of Navigation for Robotic Group	389
Mikhail Ivanov, Oleg Sergiyenko, Vera Tyshina, Lars Lindner, Miguel Reyes-Garcia, Julio Cesar Rodriguez-Quirion, Wendy Flores-Fuentes, Jesus Elfas Miranda-Vega, Moises Rivas-Lopez, and Daniel Hernandez-Balbuena	
14 Real-Time Egocentric Navigation Using 3D Sensing.....	431
Justin S. Smith, Shiyu Feng, Fanzhe Lyu, and Patricio A. Vela	
15 Autonomous Mobile Vehicle System Overview for Wheeled Ground Applications	485
Luis Carlos Basaca-Preciado, Nestor Oscar Orozco-Garcia, Oscar A. Rosete-Beas, Miguel A. Ponce-Camacho, Kevin B. Ruiz-Lopez, Verónica A. Rojas-Mendez, Cristóbal Capiz-Gómez, Julio Francisco Hurtado-Camacho, and Juan Manuel Terrazas-Gaynor	

Part IV Aerial Imagery Processing

- 16 Methods for Ensuring the Accuracy of Radiometric and Optoelectronic Navigation Systems of Flying Robots in a Developed Infrastructure 537**
 Oleksandr Sotnikov, Vladimir G. Kartashov, Oleksandr Tymochko,
 Oleg Sergiyenko, Vera Tyrsa, Paolo Merceme III,
 and Wendy Flores-Fuentes
- 17 Stabilization of Airborne Video Using Sensor Exterior Orientation with Analytical Homography Modeling 579**
 Hadi Aliakbarpour, Kannappan Palaniappan, and Guna Seetharaman
- 18 Visual Servo Controllers for an UAV Tracking Vegetal Paths..... 597**
 Jorge A. Sarapura, Flavio Roberti, Juan Marcos Toibero,
 Jose Marfa Sebastian, and Ricardo Carelli

Part V Machine Vision for Scientific, Industrial and Civil Applications

- 19 Advances in Image and Video Compression Using Wavelet Transforms and Fovea Centralis 629**
 Juan C. Galan-Hernandez, Vicente Alarcon-Aquino,
 Oleg Starostenko, Juan Manuel Ramirez-Cortes, and Pilar Gomez-Gil
- 20 Stairway Detection Based on Single Camera by Motion Stereo for the Blind and Visually Impaired..... 657**
 Javier E. Sanchez-Galan, Kang-Hyun Jo,
 and Danilo Caceres-Hernandez
- 21 Advanced Phase Triangulation Methods for 3D Shape Measurements in Scientific and Industrial Applications 675**
 Sergey Vladimirovich Dvoynishnikov, Ivan Konstantinovich Kabardin,
 and Vladimir Gennievich Meledin
- 22 Detection and Tracking of Melt Pool in Blown Powder Deposition Through Image Processing of Infrared Camera Data 711**
 Sreekar Karnati and Frank F. Liou
- 23 Image Processing Filters for Machine Fault Detection and Isolation..... 733**
 Ranjan Ganguli
- 24 Control and Automation for Miniaturized Microwave GSG Nanoproblng 751**
 Alaa Taleb, Denis Pomorski, Chi-istophe Boyaval, Steve Ai-scott,
 Gilles Dambi-ine, and Kamel Haddadi

25 Development of Design and Training Application for Deep Convolutional Neural Networks and Support Vector Machines	769
Fusaomi Nagata, Kenta Tokun o, Akiyasa Otsuka, Hiroaki Ochi, Takeshi Ikeda, Keigo Watanabe, and Maki K. Hablb	
26 Computer Vision-Based Monitoring of Ship Navigation for Bridge Collision Risk Assessment	787
Xiao-Wei Ye, Tao Jin, and Peng-Peng Ang	
About the Authors	809
Further Reading	839
Index.....	841

Contributors

Vicente Alarcon-Aquino Department of Computing, Electronics and Mechatronics, Universidad de las Americas Puebla, Cholula, Puebla, Mexico

Hadi Aliakbarpour Computational Imaging and VisAnalysis (CIVA) Lab, EECS, University of Missouri, Columbia, MO, USA

Eteزاز Abo Al-Izam Department of Computer Engineering, Faculty of Electrical and Electronic Engineering, University of Aleppo, Aleppo, Syria

Brice Allen Department of Physics and Engineering, Northwest Nazarene University, Nampa, ID, USA

Victor Andaluz Universidad de las Fuerzas Armadas, Sangolquí, Ecuador

Peng-Peng Ang Department of Civil Engineering, Zhejiang University, Hangzhou, China

Steve Arscott Univ. Lille, CNRS, Centrale Lille, ISEN, Univ. Valenciennes, UMR 8520-IEMN, Lille, France

Luis Carlos Basaca-Preciado CETYS Universidad, Mexicali, Mexico

Isela Bonilla-Gutierrez Autonomous University of San Luis Potosí (UASLP), San Luis Potosí, SLP, Mexico

Christophe Boyaval Univ. Lille, CNRS, Centrale Lille, ISEN, Univ. Valenciennes, UMR 8520-IEMN, Lille, France

Duke M. Bulanon Department of Physics and Engineering, Northwest Nazarene University, Nampa, ID, USA

Danilo Caceres-Hernandez Grupo de Sistemas Inteligentes, Facultad de Ingeniería Eléctrica, Universidad Tecnológica de Panamá, Panamá, Republic of Panamá

Cristobal Capiz-Gomez CETYS Universidad, Mexicali, Mexico

Ricardo Carelli Instituto de Automática, UNSJ-CONICET, San Juan, Argentina

Moises J. Castro-Toscano Facultad de Ingenierfa Mexicali, Universidad Aut6noma de Baja California, Mexicali, Baja California, Mexico

Cesar Chavez-Olivares Campus Sur, UAA, Aguascalientes, AGS, Mexico

Jason Colwell Department of Mathematics and Computer Science, Northwest Nazarene University, Nampa, ID, USA

Sergio Rolando Cruz-Ramirez SLP Campus, ITESM, San Luis Potosi, SLP, Mexico

Gilles Dambrine Univ. Lille, CNRS, Centrale Lille, ISEN, Univ. Valenciennes, UMR 8520-IEMN, Lille, France

Sergey Vladimirovich Dvoynishnikov Kutateladze Institute of Theoretical Physics SB RAS, Novosibirsk, Russia

Shiyu Feng Georgia Tech, School of Mechanical Engineering, Atlanta, GA, USA

Wendy Flores-Fuentes Facultad de Ingenieria Mexicali, Universidad Aut6noma de Baja California, Mexicali, Baja California, Mexico

Juan C. Galan-Hernandez Department of Computing, Electronics and Mechatronics, Universidad de las Americas Puebla, Cholula, Puebla, Mexico

Ranjan Ganguli Department of Aerospace Engineering, Indian Institute of Science (IISc), Bangalore, Karnataka, India

Pilar Gomez-Gil Department of Electronics and Computer Science, Instituto Nacional de Astrofisica, Tonantzintla, Puebla, Mexico

Emilio J. Gonzalez-Galvan Autonomous University of San Luis Potosi (UASLP), San Luis Potosi, SLP, Mexico

Maki K. Habib The American University in Cairo, Cairo, Egypt

Kamel Haddadi Univ. Lille, CNRS, Centrale Lille, ISEN, Univ. Valenciennes, UMR 8520-IEMN, Lille, France
Univ. Lille, IIT A-Departement GEII, Lille, France

Dalia Kass Hanna Department of Mechatronics Engineering, Faculty of Electrical and Electronic Engineering, University of Aleppo, Aleppo, Syria

Daniel Hernandez-Balbuena Facultad de Ingenieria Mexicali, Universidad Aut6noma de Baja California, Mexicali, Baja California, Mexico

Tyler Hestand Department of Physics and Engineering, Northwest Nazarene University, Nampa, ID, USA

Julio Francisco Hurtado-Campa CETYS Universidad, Mexicali, Mexico

Takeshi Ikeda Sanyo-Onoda City University, Sanyo-onoda, Japan

Mikhail Ivanov Universidad Autónoma de Baja California (UABC), Instituto de Ingeniería, Mexicali, BC, Mexico

Ross D. Jansen-van Vuuren Department of Chemistry, Queen's University, Kingston, ON, Canada

Tao Jin Department of Civil Engineering, Zhejiang University, Hangzhou, China

Kang-Hyun Jo Intelligent Systems Laboratory, Graduate School of Electrical Engineering, University of Ulsan, Ulsan, South Korea

Abdulkader Joukhadar Department of Mechatronics Engineering, Faculty of Electrical and Electronic Engineering, University of Aleppo, Aleppo, Syria

Ivan Konstantinovich Kabardin Khateladze Institute of Theoretical Physics SB RAS, Novosibirsk, Russia

Kenichi Kanatani Professor Emeritus, Okayama University, Okayama, Japan

Sreekar Karnati Department of Mechanical and Aerospace Engineering, Missouri University of Science and Technology, Rolla, MO, USA

Vladimir G. Kartashov Kharkiv National University of Radioelectronics, Kharkiv, Ukraine

Gabriel Kerekes Institute of Engineering Geodesy, University of Stuttgart, Stuttgart, Germany

Marina Kolendovska National University of Radioelectronics, Kharkiv, Ukraine

Vladimir G. Krasilenko Vinnytsia National Technical University, Vinnytsia, Ukraine

Alexander A. Lazarev Vinnytsia National Technical University, Vinnytsia, Ukraine

Otto Lerke Institute of Engineering Geodesy, University of Stuttgart, Stuttgart, Germany

Lars Lindner Instituto de Ingeniería Mexicali, Universidad Autónoma de Baja California, Mexicali, Baja California, Mexico

Frank F. Liou Department of Mechanical and Aerospace Engineering, Missouri University of Science and Technology, Rolla, MO, USA

Ambrocio Loreda-Flores Autonomous University of San Luis Potosí (UASLP), San Luis Potosí, SLP, Mexico

Fanzhe Lyu Georgia Tech, School of Electrical and Computer Engineering, Atlanta, GA, USA

Vladimir Genrievich Meledin Khateladze Institute of Theoretical Physics SB RAS, Novosibirsk, Russia

- Marco O. Mendoza-Gutierrez** Autonomous University of San Luis Potosi (UASLP), San Luis Potosi, SLP, Mexico
- Paolo Mercorelli** Leuphana University of Lueneburg, Lueneburg, Germany
- Jesus Elias Miranda-Vega** Universidad Autonoma de Baja California (UABC), Instituto de Ingenierfa, Mexicali, BC, Mexico
- Fablan N. Murrieta-Rico** Facultad de Ingenierfa, Arquitectura y Diseio, Universidad Aut6noma de Baja California, Mexicali, Baja California, Mexico
- Fusaomi Nagata** Sanyo-Onoda City University, Sanyo-onoda, Japan
- Diana V. Nikitovich** Vinnytsia National Technical University, Vinnytsia, Ukraine
- Connor Nogales** Department of Physics and Engineering, Northwest Nazarene University, Nampa, ID, USA
- Hiroaki Ochi** Sanyo-Onoda City University, Sanyo-onoda, Japan
- Nestor Aar6n Orozco-Garcia** CETYS Universidad, Mexicali, Mexico
- Akimasa Otsuka** Sanyo-Onoda City University, Sanyo-onoda, Japan
- Kannappan Palaniappan** Computational Imaging and VisAnalysis (CIVA) Lab, EECS, University of Missouri, Columbia, MO, USA
- Ajay K. Pandey** School of Electrical Engineering and Computer Science, Queensland University of Technology, Brisbane, QLD, Australia
- Yevhen Poliakov** Kharkiv National Automobile and Highway University, Kharkiv, Ukraine
- Oleksandr Poliarus** Kharkiv National Automobile and Highway University, Kharkiv, Ukraine
- Denis Pomorski** Univ. Lille, CNRS, Centrale Lille, UMR 9189-CRISTAL-Centre de Recherche en Informatique, Signal et Automatique de Lille, Lille, France
Univ. Lille, IUT A-Departement GEII, Lille, France
- Miguel A. Ponce-Camacho** CETYS Universidad, Mexicali, Mexico
- Juan Manuel Ramirez-Cortes** Department of Electronics and Computer Science, Instituto Nacional de Astrofisica, Tonantzintla, Puebla, Mexico
- Luis Roberto Ramirez-Hernandez** Facultad de Ingenierfa Mexicali, Universidad Aut6noma de Baja California, Mexicali, Baja California, Mexico
- Luis A. Raygoza** Centro de Ciencias Basicas, UAA, Aguascalientes, AGS, Mexico
- Miguel Reyes-Garcfa** Universidad Autonoma de Baja California (UABC), Instituto de Ingenierfa, Mexicali, BC, Mexico
- Moises Rivas-L6pez** Instituto de Ingenierfa Mexicali, Universidad Aut6noma de Baja California, Mexicali, Baja California, Mexico

Flavio Roberti Instituto de Automatica, UNSJ-CONICET, San Juan, Argentina

Julio Cesar Rodriguez-Quironez Facultad de Ingenierfa Mexicali, Universidad Aut6noma de Baja California, Mexicali, Baja California, Mexico

Ver6nica A. Rojas-Mendizabal CETYS Universidad, Mexicali, Mexico

Oscar A. Rosete-Beas CETYS Universidad, Mexicali, Mexico

Marta Rostkowska Institute of Control, Robotics, and Information Engineering, Poznan University of Technology, Poznan , Poland

Kevin B. Ruiz-L6pez CETYS Universidad, Mexicali, Mexico

Javier E. Sanchez-Galan Grupo de Investigaci6n en Biotecnologfa, Bioinformatica y Biologfa de Sistemas, Centro de Producci6n e Investigaciones Agroindustriales (CEPIA), Universidad Tecnol6gica de Panama, Panama, Republic of Panama
Institute of Advanced Scientific Research and High Technology, Panama, Republic of Panama

Jorge A. Sarapura Instituto de Automatica, UNSJ-CONICET, San Juan, Argentina

Volker Schwieger Institute of Engineering Geodesy, University of Stuttgart, Stuttgart, Ge1-many

Jose Maria Sebastian Centro de Automatica y Rob6tica , Universidad Politecnica de Madrid, Madrid, Spain

Guna Seetharaman Advanced Computing Concepts, U.S. Naval Research Laboratory, Washington, DC, USA

Oleg Sergiyenko Universidad Aut6noma de Baja California (UABC), Instituto de Ingenierfa, Mexicali, BC, Mexico

Ali Shahnewaz School of Electrical Engineering and Computer Science, Queensland University of Technology, Brisbane, QLD, Australia

Piotr Skrzypczynski Institute of Control, Robotics, and Information Engineering, Poznan University of Technology, Poznan, Poland

Justin S. Smith Georgia Tech, School of Electrical and Computer Engineering, Atlanta, GA, USA

Oleksandr Sotnikov Scientific Center of Air Forces, Kharkiv National Air Force University named after Ivan Kozhedub, Kharkiv, Ukraine

Oleg Starostenko Department of Computing, Electronics and Mechatronics, Universidad de las Americas Puebla, Cholula, Puebla, Mexico

Alaa Taleb Univ. Lille, CNRS, Centre Lille, UMR 9189-CRISTAL-Centre de Recherche en Informatique, Signal et Automatique de Lille, Lille, France

Juan Manuel Terrazas-Gaynor CETYS Universidad, Mexicali, Mexico

Juan Marcos Toibero Instituto de Automatica, UNSJ-CONICET, San Juan, Argentina

Kenta Tokuno Sanyo-Onoda City University, Sanyo-onoda, Japan

Oleksandr Tymochko Kharkiv National Air Force University named after Ivan Kozhedub, Kharkiv, Ukraine

Vera Tyrsa Universidad Aut6noma de Baja California (UABC), Facultad de Ingenierfa, Mexicali, BC, Mexico

Patricio A. Vela Georgia Tech, School of Electrical and Computer Engineering, Atlanta, GA, USA

Marek Wasik Institute of Control, Robotics, and Information Engineering, Poznan University of Technology, Poznan, Poland

Keigo Watanabe Okayama University, Okayama, Japan

Xiao-Wei Ye Department of Civil Engineering, Zhejiang University, Hangzhou, China

Abbreviations

2D	Two-dimensional
3D	Three-dimensional
4WDDMR	Four-wheeled differential drive mobile robot
AAM	Auto-associative memory
AB	Aborted
ABAC	Adaptive binary arithmetic coding
ABC	Analog-digital basic cell
ACO	Ant colony optimization
ACS	Automated control systems (Meaning in Chap. 16)
ACS	Ant colony system (Meaning in Chap. 23)
AD*	Anytime D*
ADC	Analog to digital converter
ADD	Antenna directivity diagram
AFV-SPECK	Adaptive fovea centulus set partitioned embedded block codec
AlexNet	A well-known convolutional neural network designed by Alex Krizhevsky
AM	Associative memory (Meaning in Chap. 4)
AM	Additive manufacturing (Meaning in Chap. 22)
AMCW	Amplitude modulated continuous wave
AO	Absolute orientation
AP	Antenna pattern
APD	Avalanche photo diode
API	Application programming interface
AS/RS	Automated storage and retrieval system
ASCII	American standard code for information interchange
ASIC	Application-specific integrated circuit
AVC	Advance video coding
AWFV-Codec	Adaptive wavelet/fovea centralis-based codec
BA	Bundle adjustment
BC	Basic cell (Meaning in Chap. 4)

BC	Bumper collision (Meaning in Chap. 14)
BDS	BeiDou navigation satellite system
Bel	Degree of belief
BGR	Blue green red color space
BIA	Binary image algebra
BLS	Bottommost line segments
BM	Block matching
BP	Back propagation algorithm
BPD	Blown powder deposition
bpp	Bits per pixel
CAD	Computer-aided design
CAF	Correlation analysis field
Caffe	Convolutional architecture for fast feature embedding
CAS	Computer-assisted surgery
CCC	Coefficient of cross correlation
CCCA	Current-controlled current amplifiers on current mirror multipliers
CCD	Charge-coupled device
CDF9/7	Cohen-Daubechies-Feauveau wavelet
CDNE	Complementary double NE
CENS	Channel extreme correlation navigation systems
CENS-1	CENS in which information is currently removed at a point
CENS-11	CENS in which information is currently removed from a line
CENS-III	CENS in which information is currently removed from an area (name)
CFA	Color filter array
CI	Current image
CIF	Common intermediate format
CIS	Cmos image sensors
CL	Continuous logic
CLC	Continuous logic cell
CLEM	Continuous logical equivalence model
CLF	Continuous logic function
CM	Current mirror
CML	Concurrent mapping and localization
CMM	Current multiplier mirror
CMOS	Complementary metal-oxide semiconductor
CMYK	Cyan, magenta, yellow, black color space
CNC	Computer numerical control
CNN	Convolutional neural network
CNN-CRF	Convolutional neural network-conditional random field
Cov	Covariance
CPR	Cycles per revolution
CPU	Central processing unit
CPW	Coplanar waveguide
CQDs	Colloidal quantum dots

CS	Control systems
CSM	Camera-space manipulation
C-Space	Configuration space
CUDA	Compute unified device architecture
CYM	Cnn-vature velocity method
CWT	Continuous wavelet transform
D^*	Specific detectivity (Meaning in Chap. 1)
D^*	Dynamic a^* (Meaning in Chap. 14)
D/A	Donor-acceptor
DAC	Digital-to-analog converter
dB	Decibel
DBSCAN	Density-based spatial clustering of applications with noise
DC	Digital-analog cell
DCF	Decision function
DCT	Discrete cosine transform
DF	Decision function
DGPS	Differential global positioning system
DL	Deep learning
DLP	Dwa local planner
DOEP	Digital optoelectronic processor
DOF	Degree of freedom
DoG	Difference of gradient
DSSC	Dye-sensitized solar cells
DUT	Device under test
DWA	Dynamic window approach
DWT	Discrete wavelet transform
EB	Elastic bands
ECS	Environment cooling system
EDM	Electronic distance measurement
EGT	Exhaust gas temperature
EKF	Extended Kalman filter
EM	Equivalence model
EMR	Electromagnetic radiation
EMW	Electromagnetic waves
EO	Exterior orientation
EQ_CL	Equivalent continuous-logical
EQE	External quantum efficiency
ExG-ExR	Excess green minus excess red vegetation index
FCL	Flexible collision library
FDI	Fault detection and isolation
FET	Field-effect transistor
FIP	Focus-induced photoluminescence
FIR	Finite impulse response
FIT	Frame interline transfer
FMCW	Frequency-modulated continuous wave

FNS	Fundamental numerical scheme
FO	False object
FoV	Field of vision
FPGA	Field programmable gate array
FPS	Frames per second
FR	Flying robots
FT	Frame transfer
FVHT	Fovea centralis hierarchical trees
FW	Fixed window
FWHM	Full width at half maximum
FWT	Fast wavelet transform
FW-UAV	Fixed wings unmanned aerial vehicle
G	Gi-ay
GaN nanowires	Gallium nitride nanowires
GIF	Graphics interchange format
GNSS	Global navigation satellite system
GPGPU	General purpose graphics processing unit
GPS	Global positioning system
GPU	Graphics processing unit
GRV	Gaussian random variable
GSD	Ground sampling distance
GSG	Ground signal ground
GVD	Generalized voronoi diagram
HAM	Hetero-associative memory
HD	High definition
HEVC	High efficiency video coding
HF	High frequency
HH	Horizontal histogram
HIL	Hardware-in-the-loop
HPC	High pressure compressor
HPT	High pressure turbine
HSV	Hue-saturation-value (color model)
HVS	Human visual system
Hz	Horizontal
IATS	Image-assisted total station
ICP	Integrated color pixel
1D	Identification
iDCT	Integer discrete cosine transform
IDE	Integrated development environment
IEEE	Institute of electrical and electronics engineers
IF	Infomational field
IIR	Infinite impulse response
iLWT	Inverse LWT
IMU	Inertial measurement units
INS	Inertial navigation system

IO	Interior orientation
IoT	Internet of things
IP	Image processor
IPT	Image process technology
IR	Infrared
IRNSS	Indian regional navigation satellite system
iSPECK	Inverse SPECK
IT	Information technologies
IT SB RAS	Institute of Thermophysics Siberian branch of Russian academy of Science
JBIG	Joint bi-level image group
<i>Jd</i>	Darkcurrent
JPEG	Joint photographic experts group
JPEG2000	Joint photographic experts group 2000
<i>I_{ph}</i>	Photocurrent
JSR	Just solidified region
<i>k-d</i> tree	k-dimensional tree
KF	Standard Kalman filter
KI	Integral gain
<i>K_{nn}</i>	K-nearest neighbors
<i>K_p</i>	Proportional gain
ILSVRC2012	Large-scale visual recognition challenge 2012
LCL	Lossless compression limit
LCM	Lane curvature method
LDR	Linear dynamic range
LED	Light-emitting diode
LIDAR	Light detection and ranging
LIP	List of insignificant pixels
LIS	List of insignificant sets
LoG	Laplacian of Gaussian
LPC	Low-pressure compressor
LPF	Low-pass filter
LPT	High-pressure compressor
LSP	List of significant pixels
LWT	Lifting wavelet transform
MAAM	Multi-port AAM
MAD	Mean of Absolute Differences
MAE	Mean absolute error
MAP	Maximize the Posterior estimation
MAR	Mobile autonomous robots
MATLAB	A high performance computing environment provided by MathWorks
MAV	Micro aerial vehicle
MDPG	Maximum distance of plane ground
MEMS	Microelectromechanical systems

MEO	Medium earth orbit
MHAM	Multi-port hetero-associative memory
MIMO	Multi input and multi output
MIPI	Mobile industry processIO interface
MIS	Minimally invasive surgery
MIT	Massachusetts Institute of Technology
MLA	Array of microlenses
MLE	Maximum likelihood estimator
MPEG	Moving picture experts group
MPixel	Mega pixel
MRS	Multi-robot systems
MSCA	M-estimator Sample Consensus
MSE	Mean squared error
MUTCD	Manual on uniform traffic control devices
MVS	Machine vision systems
N1	High rotor speed
N2	Low i-otor speed
NCC	NOimalized cross correlation
ND	Nearness diagram
NE	Neur-al element
NEP	Noise equivalent power
Neq	Normalized equivalence
Neqs	Neuron-equivalentors
NEU	NOith-east-up
NIR	Near infi-ared
NN	Neur-al network
NnEq	NOimalized nonequivalence
NS	Navigation system
NSEqF	Normalized spatial equivalence function
PA	Candidate area
PE	Number of areas
PL	Number of line
PP	Number of pixels
OB	Object of binding
OC	Opposite cathetus
OD	Obstacle detection
OE-VLSI	Optoelectronic very large-scale integration
OPET	Organic field-effect transistor
OHF	Organohalide pei-ovskite
OLED	Organic light-emitting diode
OPD	Organic photodiode
OPT	Organic phototransistor
OR	Object of binding
ORB	Oriented FAST and Rotated BRIEF
OSC	Organic semiconductOI

PC	Personal computer
PCL	Point cloud library
PCX	Personal computer exchange
pdf	Probability density function
PI	Proportional-plus-integral
PID controller	Proportional-integral-derivative controller
PiPS	Planning in perception space
pixel	Picture element
PL	Positioning laser
PM	Propagation medium
PNG	Portable network graphics
ppi	Pixels per inch
PPR	Pulses per revolution
PRM	Probabilistic road map
PSNR	Peak signal-to-noise ratio
PT	Phototransistor
QR	Code-quick response matrix code
RADAR	Radio detection and ranging
RANSAC	Random sample consensus
RAR	Roshal archive file format
RCS	Radar cross section
ReLU	A rectified linear unit function
RF	Radio frequency
RFBR	Russian fund of basic research
RGB	Red, green, Blue
RGB-D	Red, green, Blue depth
RI	Reference image
RLE	Run length encoding
RM	Radiometric (Meaning in Chap. 16)
RM	Recursive median (Meaning in Chap. 23)
RMI	Radiometric imaging
RMS	Root mean square
RMSE	Root mean square error
RO	Relative orientation
ROI	Region of interest
ROIC	Read-out integrated circuitry
ROS	Robot operating system
ROV	Remotely operated vehicle
RRT	Rapidly exploring random tree
RTS	Robotic total station
RW-UAV	Rotary wings unmanned aerial vehicle
S/R	Storage and retrieval
SA	Scanning aperture
SAD	Sum of absolute differences
SAE	Society of automotive engineers

SD	Standard deviation
SD_NEF	Spatially dependent normalized equivalence function
SDPN	Sensors of different physical nature
SE(2)	Special Euclidean group for two-dimensional space
SE(3)	Special Euclidean group for three-dimensional space
SEM	Scanning electron microscope
SfM	Structure from motion
SGBM	Semi-global Block matching
SHD	Sample and hold device
SHM	Structural health monitoring
SI	Source image
SIEMAM	Spatially invariant equivalence model associative memory
SIFT	Scale invariant feature transform
SLAM	Simultaneous localization and mapping
SLECNs	Self-learning equivalent-convolutional neural structure
SM	Simple median
SMC_ADC	Multi-channel sensory analog-to-digital converter
SMO	Sequential minimal optimization algorithm
SoC	System on a chip
SPAD	Single-photon avalanche diodes
SPECK	Set partitioned embedded Block codec
SPIHT	Set partitioning in hierarchical tree
sRGB	Standard Red, Green, Blue color space
SS	Sighting surface
SSD	Sum of squared differences
SSIM	Structural similarity index
STP	Spanning tree protocol
SURF	Speeded-up robust feature
SVD	Singular value decomposition
SVM	Support vector machine
SWNT	Single walled nanotube
Te	Transfer characteristics
TCC	Turbine cooling casing
TCP/IP	Transmission control protocol/Internet protocol
TEB	Timed elastic bands
TensorFlow	An open source software library which can be used for the development of machine learning software such as neural networks
TFD	Transverse field detector
TFLOPS	Tera floating point operations per second
TLS	Total least squares algorithm
TM	Trademark
TNM	Technical navigation means
TO	Time-out
ToF	Time of flight
TPCA	Time-pulse-coded architecture

TSR	Traffic sign recognition
TVS	Technical vision system
UABC	Universidad Autonoma de Baja California
UAV	Unmanned aerial vehicle
UGV	Unmanned ground vehicle
UKF	Unscented Kalman filter
UL	Unit load
ULE	Universal (multifunctional) logical element
USB	Universal serial bus
V	Vertical
vAOV	Vertical angle of view
Var	Variance
VFH	Vector field histogram
VH	Vertical histogram
VIRAT	DARPA video and image retrieval and analysis tool
VMO	Vector or matrix organization
VNA	Vector network analyzer
VO	Visual odometry
YPH	Vector polar histogram
VSLAM	Visual simultaneous localization and mapping
WAAS	Wide area aerial surveillance
WAMI	Wide area motion imagery
WAPS	Wide-area persistent surveillance
WebP	Webp
WF	Fuel flow
WFOV	Wide field of view
WRM	Weighted recursive median
WT	Wavelet transform
Y'CbCr	Luma Chrominance color space
ZIP	.ZIP file format

Design and simulation of array cells of mixed sensor-processors for intensity transformation and analog-digital coding in machine vision

Vladimir G. Krasilenko, Alexander A. Lazarev, Diana V. Nikitovich

Vinnitsia National Technical University, Ukraine.

Abstract

The urgent need to create video sensors and processors for parallel (simultaneous by pixel) image processing with advanced functionality and multi-channel picture outputs is showed in the chapter. We consider perspective spheres and areas of application of such sensor-processors, in particular, for hardware high-performance architectures of neural networks, convolutional neural structures, parallel matrix-matrix multipliers and special-processor systems. We show and analyze the theoretical foundations, the mathematical apparatus of matrix and continuous logic, their basic operations, show their functional completeness, evaluate their advantages and prospects for application in the design of biologically inspired devices and systems for processing and analysis of array signals. We show that some functions of continuous logic, including operations of normalized equivalence of vector and matrix signals, operation of a limited difference in continuous logic, are a powerful basis for designing improved smart micro-cells for analog transformations and analog-digital encodings. In the next sections of the chapter, we consider in more detail the design and modeling aspects of such micro-basic cells and continuously-logical high-speed ADCs based on them. The picture type ADC consists of an array of parallel operating channels, each of which is a basic microcell or a set of them. The basic microcell of a 2D ADC structure consists of several digital-analog cells (DC), which is made on 15-35 CMOS transistors. For an iterative type ADC, only one DC cell is needed, which is DC- (G) and additionally contains a sample and hold device (SHD). In this case, the entire base microcell can be performed on just 35 CMOS transistors. A single ADC channel cell with iteration has a serial-parallel output code. For a non-iterative type ADC, its base microcell may consist of such a quantity of DC, which depends on the digit capacity of the code. To simulate the proposed schemes, we used OrCAD, and the results are presented below. Conversion time with 6-8-bit binary codes or Gray codes and an input photocurrent range of $0.1 \div 24\mu\text{A}$ is $20 \div 30\text{ns}$ at a supply voltage of $1.8 \div 3.3\text{V}$. If the maximum input current is $4\mu\text{A}$, then for ADC with iteration total power consumption was only $50 \div 100\mu\text{W}$. Low power consumption at such a supply

voltage, and good dynamic characteristics (the digitization frequency even for 1.5 μ m CMOS technologies is 40 ÷ 50MHz) shows good prospects, since the structure of the linear array of ADCs and its micro cells are very simple. The conversion frequency can be increased 10 times with more advanced CMOS transistors. Thus, the proposed ADC based on CL BC and CM are promising for creating photoelectric structures with matrix operands, digital optoelectronic processors, linear and matrix image processors (IP) and other neural-like structures that are necessary for neural networks, neuro-fuzzy controllers. In the chapter, we will consider a generalized method of designing devices for nonlinear transformation of the photocurrent intensity using a set of similar basic modified cells and their circuits implemented using traditional CMOS technology. To implement the required nonlinear transformation function, we use the decomposition method. The type of synthesized functions is determined by the choice of suitable parameters, which are specified as constants or as parameters with which you can choose or change the type of nonlinear transformation. In the chapter we will also show the need for different types of nonlinear intensity conversion of photocurrents and different codes (gray, binary) for AD conversion in such parallel sensor devices and systems, especially for implementing various types of activation functions in hardware implementations of neural networks, consider the use of such parallel matrix arrays to create progressive IP and neural networks (NN). The cells offered by us have a low supply voltage of 1.8 ÷ 3.3 V, low power consumption (microwatts), the conversion time is less than 1 μ s, and consist of several dozen transistors. We also consider the cells for the implementation of various neuron activation functions in neural networks and transient nonlinear conversion with characteristics of S-, N- and λ - types. In conclusion, we make estimates and show the prospects for such approaches to the design of sensor processors.

Keywords: continuous logical ADC, image processor, multi-channel sensor systems, current mirror, equivalence (non-equivalence) functions, methods of selection and rank preprocessing, self-learning equivalent-convolutional neural structures, equivalent models, continuous-logical operations, 2D spatial function, neuron-equivalentor, image intensity transformation, nonlinear processing.

INTRODUCTION

To create biometric systems, computer vision systems are needed to solve the problem of recognizing objects in images. There are many known methods and means to address these problems [1, 2]. In most recognition algorithms, the most frequently used operation is the comparison of two different images of the same object or its fragments. The mutual 2D function of correlating a reference fragment with the current offset image fragment is also most often used as a

discriminant measure of their mutual comparison. With a strong correlation of images in their set to improve the accuracy and probability, the quality of comparison of the noisy current fragment and the reference image, as shown in [3], it is desirable to use methods of comparison, image selection, based on measures of mutually equivalent two-dimensional spatial functions transformations and adaptive correlation weightings. Various models of neural networks (NN) are actively used as a tool for image recognition and clustering. The latter are also widely used for modeling pattern recognition, biometric identification, associative memory (AM), and control of robotic devices. In [4, 5], equivalence models (EM) of auto-associative memory (AAM) and hetero-associative memory (HAM) were proposed. The EMs have an increased memory capacity (3-4 times higher than the number of neurons) relative to the number of neurons (4096 and more) and the ability to compare, store and retrieve to recognize strongly correlated and noisy images of large dimension, as was shown in [6 - 8]. These models allow you to recognize fragments (64x64 and more) with a significant percentage (up to 25-30%) of damaged pixels [5, 7, 9, 10]. Models of multi-port AAM (MAAM) and multi-port heteroassociative memory (MHAM) for associative image storage and recognition were investigated in [7, 8], the main idea of which was originally published in [4]. Mathematical models and AM implementations based on EMs were initiated in [4] and described in detail in papers [7 - 9], and their modifications in [11–13]. For analysis and recognition, the problem of clustering various objects must be solved. This previous clustering allows you to organize the correct automated grouping of the processed data, conduct cluster analysis, evaluate each cluster on the basis of a set of attributes, put a class label and improve subsequent classification and recognition procedures. The significant advantages of EM in creating on their basis MAAM and MHAM [8, 11, 12], improved neural networks [5 - 9] made it possible to suggest new modifications of MHAM for parallel cluster image analysis [11 - 12] and their hardware implementations on parallel structures, matrix-tensor multipliers, equivalentors with spatial and temporal integration [8, 9, 12 - 14]. Spatially non-invariant models and their implementation for image recognition and clustering were considered in [8, 12] and only in [1, 2, 9, 11], spatial-invariant image recognition models were considered, but not clustering. More generalized spatially invariant (SI) equivalence models (EMs) are invariant to spatial displacements, can be used for clustering images and their fragments, and therefore the study of such models is an urgent task [14-17]. In addition, as our analysis shows, these models, described in our works [1-10] and known for more than 20 years, are very closely related to the operations of convolution of images. In the most promising paradigms of convolutional neural networks (CNN) with deep learning [18–24], the main operation is convolution. But they reveal regularities on the basis of existing patterns or filters require complex computational procedures in their training. Jim Cruchfield of UC Davis and his team are exploring a new approach to machine learning based on pattern discovery. Scientists create algorithms to identify previously unknown structures in data, including those whose complexity exceeds human understanding. New

possible ways of self-learning based on such advanced models were considered in [25]. It explained on the basis of understanding the principles of functioning of biological neural structures some important fundamental concepts, mechanisms of associative recognition and modeled the processes of transformation and learning. Patterns were identified in such models for binary slices of digitized multi-level images, and their implementations were proposed, and in article [26] for multilevel images without prior binarization. But, as will be explained below, for all progressive models and concepts, nonlinear transformations of signals, image pixel intensities are necessary.

The bottleneck between the processor and the memory or processors is too slow interconnects. The increase in the integration density of devices further aggravates the problem, since more channels are required for communication outside the crystal. The use of optical interconnects is discussed as an alternative to solve the problems mentioned. The use of optics or optoelectronics for interconnects outside the crystal and inside the crystal was demonstrated in [27]. This problem in such OE-VLSI is solved by implementing external interconnects not with the edge of the chip, but with arrays of optical detectors and light emitters, which allows to implement the stack architecture of a three-dimensional chip [28]. But in this case, the combination of various passive optical elements with active optoelectronic and electronic circuits in one system is also an unsolved problem. Intelligent detector circuits can be thought of as a subset of OE-VLSI circuits. They consist only of arrays of photo detectors, which can be monolithically integrated with digital electronics in silicon, and circuits for analog-digital conversion. This greatly simplifies the design of OE-VLSI circuits, which additionally must contain only light-emitting devices, and the latter can also be implemented in silicon [29]. Such intelligent detectors with a frame [30] show a large scope and market potential. In this regard, our approach also relies on an intelligent pixel-like structure combining parallel detection of signals with parallel processing of signals in a single circuit. To realize the fastest processing, each pixel has its own analog and analog-digital node. One of the important directions for solving various scientific problems is parallel processing of large arrays (1D or 2-D) of data using non-traditional computational MIMO-systems and matrix logics (multi-valued, sign, fuzzy, continuous, neuro-fuzzy, etc.) and the corresponding mathematics [31 - 34]. Realizations of optical learning neural networks (NN) with a two-dimensional structure [31], continuous logical equivalence models (CLEM) NN [32 - 34] require elements of matrix logic as well as an adequate structure for vector-matrix computing procedures. Advanced parallel computing structures and processors with time-pulse signal processing [35] require parallel processing and parallel inputs/outputs. The generalization of scalar two-valued logic on the matrix case led to the intensive development of binary image algebra (BIA) [36] and logical elements of a two-dimensional array for optical and optoelectronic processors [33, 35, 37 - 39]. One of the promising areas of research is the use of time-pulse-coded architectures (TPCA), which were considered in papers [40, 41], which, through the use of two-level optical signals,

not only increase functionality (up to universality), increase noise immunity, stability and reduce the requirements for alignment and optical system, but also simplify the control circuit and settings for the required functions, and keep intact the entire methodological basis of these universal elements regardless of the length of the code word and the type of logic. Mathematical and other theoretical foundations of universal (multifunctional) logical elements (ULE) of the matrix logical design with a fast programmable setting, where the unification of functional bases is expedient and the need to use ADC arrays were considered in [42, 43]. An ADC is a continuous-discrete automaton that performs the conversion of an analog value x by its interaction with standard sizes in a discrete output code. Aspects of the theory and practice of designing and using ADCs and DACs are so broadly outlined that it is even difficult to choose the most general works. At the same time, in the last 20-30 years, optical methods and means for parallel digital image processing have been intensively investigated, which, unlike analog ones, have high accuracy and a number of significant advantages. Certain success has been achieved in the field of creating two-dimensional matrix logic devices, storing image-type data for such parallel information systems and digital optoelectronic processors (DOEP) [38] with a performance of 10^{12} - 10^{14} bits per second. Most vector-matrix and matrix-matrix multipliers [39] use 1D-linear and 2D-matrix multi-channel ADC [43-45]. A bottleneck in parallel DOEP is an ADC, which, unlike traditional input systems with scanning or sequential-parallel reading and output, must in parallel fully perform ADC conversion of a large number of signals (256×256 pixels or more) and provide an input speed of up to 10^6 - 10^7 frames per second. Therefore, there is a need of multichannel ADC with several parallel inputs and outputs, with vector or matrix organization (VMO) [43-45], and the channels operate in parallel and provide low power consumption, simple circuit implementation, short transformation time, low input level, acceptable word length, etc. In addition, such a VMO ADC can also perform other functions, for example, the computation of logical matrix operations, digital filtering, and digital addition-subtraction of images. For multichannel multisensor measuring systems, especially for wireless ones, ADCs with very low consumption, high accuracy and speed are required. In papers [46 - 52] design of ADCs, current comparators and their application were considered. But these comparators are very high speed, consist of many transistors and have high consumption power. Equivalent (EQ) continuous-logical (CL) ADC, which was considered in [43 - 45, 51], provided high performance with a smaller amount of equipment, since it consisted of n series-connected analog-digital basic cells (ABC). Such cells implement CL-functions on CMOS-transistors operating in the current mode. The parameters and performance of such CL ADCs, including the type of output codes, are influenced by the selection of the required continuous-logic functions for the analog-digital conversion and the corresponding ABC scheme. The simplicity of these CL ADCs makes it possible to realize a significant number of multi-channel converters for optical parallel and multisensor systems. The proposed CL ADC schemes are more preferable specifically for such applications where parallelism and large size arrays are required. Based on the

above, the purpose of our chapter is to design and simulate various variants of the technical implementation of continuously logical basic cells (CL BC) based on current mirrors (CM) and multi-channel sensory analog-to-digital converters (SMC ADC) with the functions of preliminary analog and subsequent analogue digital processing for image processors (IP) and sensor systems. In addition, in our previous works, the accuracy characteristics of the ADC were not considered, no estimates of conversion errors were made for different possible modes and modifications of such basic cells and ADCs as a whole. That is why the purpose of the present work is also to evaluate ADC errors, demonstrate them by specific experimental results, and also further enhancements of such ADCs and their basic cells, which significantly expand their functionality and the range of problems they solve.

1 SIMULATION OF ARRAY CELLS FOR IMAGE INTENSITY TRANSFORMATIONS AND THEORETICAL MATHEMATICAL BACKGROUND

1.1 Substantiation of the need to design devices for parallel nonlinear image intensity transformations in self-learning equivalent-convolutional neural structures (SLECONS)

For neural networks and associative memory systems, generalized equivalence models using the functions of non-linear normalized equivalences of matrices and tensors were developed. They use spatially dependent normalized equivalence functions (SD_NEF) [6], which are defined as:

$$\tilde{z}(A, B) = \frac{A \tilde{*} B}{I \times J} = \frac{1}{I \times J} \sum_{i=1}^I \sum_{j=1}^J (a_{\zeta+i, \eta+j} \sim b_y),$$

where $\tilde{\mathbf{e}} = [e_{\zeta, \eta}] \in 0, 1^{N-I+1 \times M-J+1}$, and symbol $\tilde{*}$ indicates a spatial convolution, but with an element-wise operation of not multiplication, but "equivalence". In accordance with the principle "the strongest survives" and the strengthening of the non-linear action of the components, depending on the level of their values, the elements of matrix $\tilde{z}(e)$ and of other intermediate SD_NEF are transformed using of auto-equivalence operations [13] with different parameters p_1, p_2 . The higher the parameters p_1, p_2 in p-step auto-equivalence, that is, the more "competing" nonlinear transformations, the faster the process of recognition and state stabilization, as studies show with the help of energy equivalent functions [6, 26, 53]. The number of iterations necessary for successful

recognition depends on the model parameters and, as experiments show, is significantly smaller compared to other models and does not exceed just a few. Changing the parameters p_1, p_2 it is possible to obtain all the previously known EMs [5-13]. To implement the proposed new subclass of associative neural systems, certain new or modified known devices are needed that can calculate the normalized spatial equivalence functions (NSEqFs) with the necessary speed and performance [1, 6, 10]. We called such specialized devices the image equivalentors [4, 6, 9, 10, 13], which are, in essence, a doubled correlator [54] or a doubled convolver. For the input image S_{inp} , learning array-matrix \mathbf{A} , which is a set of reference images, the general SI EM AM is proposed [11, 14, 15] and modeled, where after the first and the second steps of the algorithm the element-wise equivalence convolution and nonlinear transformations were calculated. Research results of the generalized SI EM AM confirmed advantages and improved characteristics and possibility to recognize with interferences up to 20-30% [14, 15]. In works [12, 14] described a clustering method based on the simultaneous calculation of the corresponding distances between all cluster neurons and all training vectors using such MAAM and MHAM. As metrics, we use generalized non-linear normalized vector equivalence functions, which gives good convergence and high speed of models, see papers [12, 14-17]. An iterative learning process that uses a learning matrix and consists in calculating the optimal set of weight vectors for all cluster neurons is described by the proposed model. Optimal patterns are formed by such an iterative procedure, based on the search for patterns and tangible fragments of objects that are in the set of trained images. Patterns of recognition and clustering of images that combine the learning process with the process of recognition are proposed in [25, 26]. For our EMs and all known convolutional neural networks, it is necessary to determine the convolutions of a large number of patterns from the set of standards with the current image fragment in each layer in the learning process. Large images require a large number of filters for image processing, as studies show, and the size of filters also, as a rule, is also large. Therefore, the acute problem is to significantly improve the computational performance of such CNN. Therefore, the last decade was marked by the activation of work aimed at creating specialized neural accelerators, which calculate the comparison function of two two-dimensional arrays and use the multiplication and addition-accumulation operations. Unlike most papers, in our works we use those functions of normalized equivalence in which there is no multiplication operation. But, as our studies show, equivalent models also allow us to construct convolutional equivalence structures and self-learning systems. Therefore, using our approaches to the construction of a one-dimensional neuron-equivalentor [55 - 58], we considered the structure of a two-dimensional neuron-equivalentor, generalized for processing two-dimensional arrays. The block diagram of the main unit of self-learning equivalent convolutional neural structures (SLECNS) [26] is shown in Fig. 1 (a). The required number of convolutions $e_0 \div e_{n-1}$, depending on the number of filter templates $\mathbf{W}_0 \div \mathbf{W}_{n-1}$, is formed from the matrix \mathbf{X} . Convolutions are

represented by matrices with multilevel values, unlike binary ones, which we used earlier. Each filter is compared with the current fragment of the matrix, and equivalent measures of proximity or other measures, such as a histogram, are used as a measure of the similarity of the fragment of matrix \mathbf{X} and the filter. Therefore interpretation method for spatially invariant case requires the calculation of spatial features convolution-type $\mathbf{E}^m = \mathbf{W}^m \otimes \mathbf{X}$, where $E_{k,l}^m = 1 - \text{mean} \left[\text{submatrix } \mathbf{X}, k, k+r_0-1, l, l+r_0-1 - \mathbf{W}^m \right]$, nonlinear processing by the expression $EN_{k,l}^m = G \left(a, E_{k,l}^m \right) = 0,5 \left[1 + 2E_{k,l}^m - 1^a \right]$ and comparing each other to determine the winners for indexing expressions: $MAX_{k,l} = \max_{index m} EN_{k,l}^{m=0}, EN_{k,l}^{m=1} \dots EN_{k,l}^{m=M-1}$ and $EV_{k,l}^m = f_{nonlinear}^{activ} EN_{k,l}^m, MAX_{k,l}$. Thus, in the first and second steps, it is necessary to calculate a large number of convolutions. From the above formulas it follows that it is necessary to calculate the average value of the component-wise difference of two matrices. Similarly, normalized nonequivalent functions for all filters are calculated, and their components are nonlinear transformed: $\mathbf{EN}_{\mathbf{k},1} = 0,5 \left[1 + |2 \cdot \mathbf{E}_{\mathbf{k},1} - 1|^\alpha \right] \cdot 255$, where α is the nonlinearity coefficient. Based on these transformations for SLECONS, we need to implement nonlinear transformations for different α . The analysis of this expression shows that it is necessary to raise to power, multiply, so we propose to approximate this dependence, for example by three-piece linear approximation. The conducted experiments in work [26] show great promise of the proposed methods and models of self-learning-recognition of images, including multilevel and color images. But for their work in real time, taking into account the large requirements for performance and the amount of calculations, it is necessary to have appropriate high-performance and energy-efficient arrays and image processors with parallel principles of operation and picture input-outputs, whose design was partially considered in papers [9, 12, 13, 58 - 61, 63 - 65]. In fig. 1 (b) a new structure proposed by us in [66] is shown, which may be promising for use in machine vision and artificial intelligence, neural structures, in various high-performance measurement systems [67 - 69]. The presented structure makes it possible to calculate in parallel the set of all components (elements) of the equivalent convolution at once in a single cycle at high speed. The cycle time is equal to the time of selection from the processed image of its shifted current fragment. The structure of the system that uses an array of neuron equivalents consists of a microdisplay that dynamically displays the current fragments, an optical node as an array of microlenses (MLA) with optical lenses (not shown!), and a two-dimensional array of equivalentors (Eqs) with optical inputs. Each Eq is implemented in a modular hierarchical manner and can consist of similar smaller sub-pixel, also 2D type, base nodes. The equivalentor has a matrix of photodetectors, on which a halftone image of a fragment is projected using (MLA). The number of electrical analog inputs is equal to the number of photo

detectors, to which the filter components are fed from a sampling and holding device (SHD) or analog memory with subsequent digital-analog conversion using any known method.

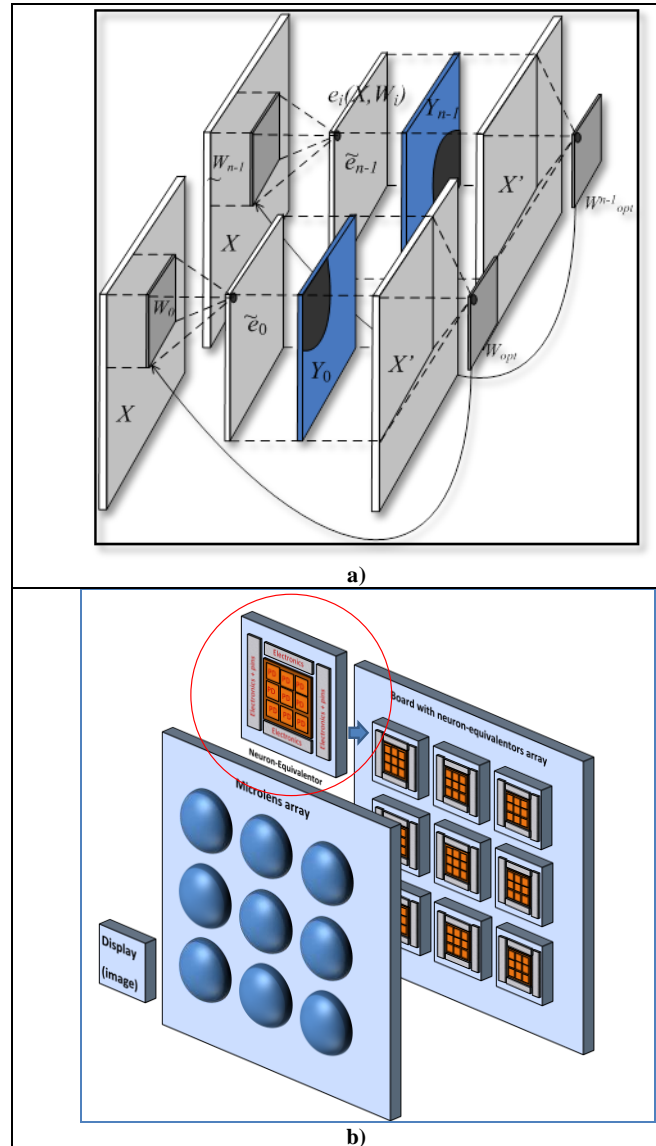

Fig. 1. The basic unit (structure) of the SLECONS, which explains the principle of its functioning of learning neural network model based on the multi-port memory to find centroid cluster elements (a); The basic unit that uses an array of neuron-equivalentors (b)

These components are presented in the form of microcurrents. Each equivalentor has its own filter mask from the filter set, which is formed as a result

of training. Simulation on 1.5 μ m CMOS transistors in various modes showed that such equivalentor and their basic blocks can operate in low-power and high-speed modes, their energy efficiency is estimated to be at least 10^{12} an. op / sec per watt and can be increased by an order of magnitude, especially considering FPAA [62]. But much depends on the accuracy of the current mirrors and their characteristics. Thus, at the inputs of each equivalentor there are two arrays (vectors) of analog currents representing the current fragment being compared and the corresponding filter standard, and the output of the equivalentor is an analog current signal that is nonlinearly transformed in accordance with the activation function and represents a measure of their similarity, proximity. Also, as have been shown [66], non-linear component-wise transformations allow even without WTA network to allocate the most NEs with the greatest activity. From the above described it follows that for hardware implementations of all the advantages of SI EM, an important issue is the design of parallel nonlinear transformations, transformations of intensity levels. And, as will be shown below, the use of an array of cells that perform hardware and not with PC, non-linear transformations adequate to auto-equivalence operations, allows the laborious computational process of searching for extremums in SD_NEF (maps for clustering and learning) not to be performed, but to automatically select these extremums using only several transformations steps and eliminate all unnecessary levels, making these levels pixels neutral for subsequent algorithmic steps.

1.2 Brief review and background of mathematical operators, which are implemented by neurons

Almost all concepts, models, structures of NN, CNN use informational mathematical models of neurons, which are reduced to the presence of two basic mathematical components-operators: the first component computes a function from two vectors \vec{X} and \vec{W} , where \vec{X} - vector of input signals of a neuron, \vec{W} - vector of weights, and the second component corresponds to some nonlinear transformation of the output value of the first component to the output signal. The input operator can be implemented as sum, maximal or minimum value, product of the self-weighted inputs [55, 56]. But recently, the set of such operators has expanded significantly [6, 9, 13, 56]. Equivalence models of neural networks, which have some advantages, require the computation of such operators: normalized equivalence (NEq), nonlinear normalized nonequivalence (NnEq), autoequivalence of vectors. In [9, 13, 57], we considered how to implement these input operators for the case when the components of the vectors \vec{X} and \vec{W} are both normalized and unipolarly encoded. In work [58] we used just normalized equivalences, but time-pulse coding was used for analog signals. The positive aspect of that work was the use of a modular principle that allowed the calculation

of the operator of the normalized equivalence of a vector to the calculation of normalized equivalent sub-vectors and their output signals. In paper [58] the mathematical basis of creation of neurons of equivalents calculating the function of NEq is described in detail, using the modular principle. To increase the number of inputs of our complementary double NE (CDNE) or the dimension of the compared vectors, you can use the combination of the basic analogue CDNE of a smaller dimension. This greatly expands the functionality of such a basic CDNE, especially when they are combined in complex hierarchical structures. It shows that all algorithmic procedures in the equivalence paradigm of NNs and AM on their basis are reduced to the calculation of NEqs from two vectors or matrices, and the elemental nonlinear transformations that correspond to the activation functions, and for the above EMs of NNs, reduce to the calculation of auto-equivalences (auto-non-equivalences). But in the above works, activation functions were not simulated and shown. A lot of work has been devoted to the design of hardware devices that realize the functions of activation of neurons, but they do not consider the design of exactly the auto-equivalent transformation functions for EMs and the most common arbitrary types and types of nonlinear transformations. Therefore, the goal of this paper is the design of cells for hardware parallel transformation of image intensity levels. In work [66], the question of the simplest approximations of auto-equivalence functions (three-piece approximation with a floating threshold) was partially solved. The basic cell of this approximation consisted of only 18 - 20 transistors and allowed to work with a conversion time from 1 to 2.5 μ s. At the same time, the general theoretical approaches to the design of any nonlinear type of intensity transformation were not considered, and this is the object of the paper. The operations of addition and subtraction of currents are most easily performed on current mirrors.

1.3 Mathematical models of nonlinear transformations of image intensities

The input analog intensity of the pixel is denoted by x , where $x \in 0, D$, D – the maximum intensity of the selected range, and denote the output analogized transformed intensity by y , where $y \in 0, D$. Then the operator of the nonlinear intensity transformation can be written in the form: $y = F_{trans} x$. As such functions can be threshold processing functions, exponential, sigmoid and many others, which, in particular, are used as activation functions in the construction, synthesis of neural elements and networks based on them. To form the required nonlinear intensity transformations, it is possible to use piecewise linear approximation of the chosen functions. For piecewise-linear approximation, break the range of input levels D into N equal sub-bands, width $p = D/N$. Using the function of bounded difference known from papers [6, 13], defined as

$a \dot{\div} b = \begin{cases} a-b, & \text{if } a > b \\ 0, & \text{if } a \leq b \end{cases}$. Form for the input signal x and each upper sub-band level

$pD_i = i \cdot p$, where $i = 1 \dots N$, the following signals: $s_i = x \dot{\div} (i-1)p \dot{\div} (x \dot{\div} i \cdot p)$.

For $i = 1$ we get $s_1 = x \dot{\div} (x \dot{\div} p)$, and this is the minimum $\min(x, p)$ and there is a step signal with height p . For $i = 2$ we get $s_2 = (x \dot{\div} p) \dot{\div} (x \dot{\div} 2p)$, which corresponds to a step in height p , but which begins at p . For $i = N$ we get $s_N = x \dot{\div} (N-1)p \dot{\div} (x \dot{\div} N \cdot p) = (x \dot{\div} (N-1)p)$, which corresponds to a step in height p , but which begins at $(N-1)p = D - p$. Summing with the weight coefficients k_i these steps, we can form a piecewise approximated intensity

$$y_a = \sum_{i=1}^N k_i s_i = \sum_{i=1}^N k_i (x \dot{\div} (i-1)p) \dot{\div} 2(x \dot{\div} i \cdot p) , \quad (1)$$

for forming $y_a \in 0, D$, that is, the normalized range of its levels, the weighting

coefficients of the steps are selected from the condition: $\sum_{i=1}^N k_i = N$. Analysis of

formula (1) shows that by changing the gain of the steps, we can form any required piecewise continuous intensity conversion function. If the coefficient k_i negative, it means that the corresponding step is subtracted. Thus, in order to implement the transformations, a set of nodes for realizing operations of bounded difference, weighting (multiplication), and simple summation are needed. If the input pixel intensity is set by the photocurrent, then having the current mirrors (CM), by which the operations of the limited difference and the summation of the photocurrents are easily realized, it is sufficient to have a plurality of limited difference schemes and the specified upper sub-band levels pD_i . By choosing the parameters of the current mirror transistors, operations of dividing or multiplying currents by the required fixed k_i . If it is necessary to dynamically change the view, the conversion function, i.e. the weight of the components, then you need the coded amplifiers. When working with currents and CM, a set of keys and a multiplying mirror with discrete weights (binary) perform the role of code-controlled amplifiers and are essentially DAC with the only difference that instead of a reference analog signal an analog signal s_i . After some transformations, formula (1) is transformed to this form:

$$y_a = \sum_{i=1}^N k_i (x \dot{\div} pD_{i-1}) \dot{\div} 2(x \dot{\div} pD_i) = \sum_{i=1}^N k_i \cdot \min(x \dot{\div} pD_{i-1}, p) \quad (2)$$

Formula (2) indicates that for the implementation of the intensity conversion, it is necessary to have analogous minimum circuits, but it is realized in the form of two operations of bounded difference: $a \dot{\div} (a \dot{\div} b) = \min(a, b)$. In addition to the formulas (1) and (2) considered above, it is possible to realize the required function by means of triangular signals:

$$y_a = \sum_{i=1}^N k_i \cdot t_i = \sum_{i=1}^N k_i (x \div (i-1) \cdot p) \div 2(x \div i \cdot p) \quad (3)$$

For the formation of the constants s_i or t_i , the input signal x can be multiplied by N and then all components are simultaneously generated simultaneously in each sub-assembly. On the other hand, in each sub-assembly a signal $(x \div pD_i)$, this is fed to the next in the pipeline sub-assembly for the formation of signals and components from it. This corresponds to a conveyor circuit that will have a large delay, but does not require the multiplication of the input signal. The choice of this or that scheme and element base depends on the requirements for the synthesized node.

1.4 Simulation of array cells for image intensity transformation

1.4.1 Simulation of image intensity transformation with Mathcad

Using both the basic components for the composition of the lambda function **fspΔs2**, shown in Fig. 2 and described by expression: $\mathbf{fsp}\Delta\mathbf{s}2[\mathbf{x}\mathbf{s}, \mathbf{p}\Delta\mathbf{x}, \mathbf{p}\Delta, \mathbf{k}] := \mathbf{k} \cdot \mathbf{obs}[\mathbf{obs}[\mathbf{x}\mathbf{s}, \mathbf{p}\Delta\mathbf{x}], \mathbf{obs}[\mathbf{x}\mathbf{s}, \mathbf{p}\Delta] \cdot 2]$, where $\mathbf{x}\mathbf{s}$ -function argument, $\mathbf{p}\Delta\mathbf{x}$ - parameter indicating the lower bound-level $\mathbf{x}\mathbf{s}$ (beginning), $\mathbf{p}\Delta$ - the second parameter indicating the level for the maximum, \mathbf{k} - is the third parameter indicating the scalar gain multiplier; and $\mathbf{abs}(a, b) = a \div b$ we proposed a function-composition **fspΔsS**, which is calculated by the expression:

$$\mathbf{fsp}\Delta\mathbf{s}\mathbf{S}[\mathbf{x}\mathbf{s}, \Delta\mathbf{k}, \mathbf{V}\mathbf{K}] := \sum_{\mathbf{i}=1}^{\Delta\mathbf{k}} \mathbf{fsp}\Delta\mathbf{s}2\left[\mathbf{x}\mathbf{s}, \frac{255}{\Delta\mathbf{k}} \cdot (\mathbf{i} - 1), \frac{255}{\Delta\mathbf{k}} \cdot (\mathbf{i}), \mathbf{V}\mathbf{K}_{\mathbf{i}}\right],$$

where $\Delta\mathbf{k}$ - number of components (lambda functions), $\mathbf{x}\mathbf{s}$ - argument of the function, $\mathbf{V}\mathbf{K}$ -vector of gain factors. The result of constructing some types of transfer characteristics (TC) using these functions in the Mathcad environment is shown in Fig. 2. To approximate auto-equivalence, we also offer simpler (2-step) basic N-functions:

$$\mathbf{af}(\mathbf{x}\mathbf{s}, \mathbf{x}\mathbf{p}) := [\mathbf{obs}(\mathbf{x}\mathbf{s}, \mathbf{obs}(\mathbf{x}\mathbf{s}, \mathbf{x}\mathbf{p})) + \mathbf{obs}[\mathbf{x}\mathbf{s}, (\mathbf{D}\mathbf{P} - \mathbf{x}\mathbf{p})]] \cdot \left(\frac{\mathbf{D}\mathbf{P}}{\mathbf{x}\mathbf{p} \cdot 2}\right)$$

and triple their composition:

$$\mathbf{afS}(\mathbf{xs}, \mathbf{VaF}, \mathbf{KaF}) := \sum_{\mathbf{iv} = 0}^2 \mathbf{af}(\mathbf{xs}, \mathbf{VaF}_{\mathbf{iv}}) \cdot \|\mathbf{KaF}_{\mathbf{iv}}\|. \text{ In general, the number of}$$

components in a composition can be arbitrary, but for modeling we used 8 and 16 component compositions and adjustment vectors. Examples of such functions and compositions for the synthesis of TC are shown in Fig. 3. Another variety of functions is shown in Fig. 4, and the results of using such TCs to prepare the original PIC image are shown in Fig. 5.

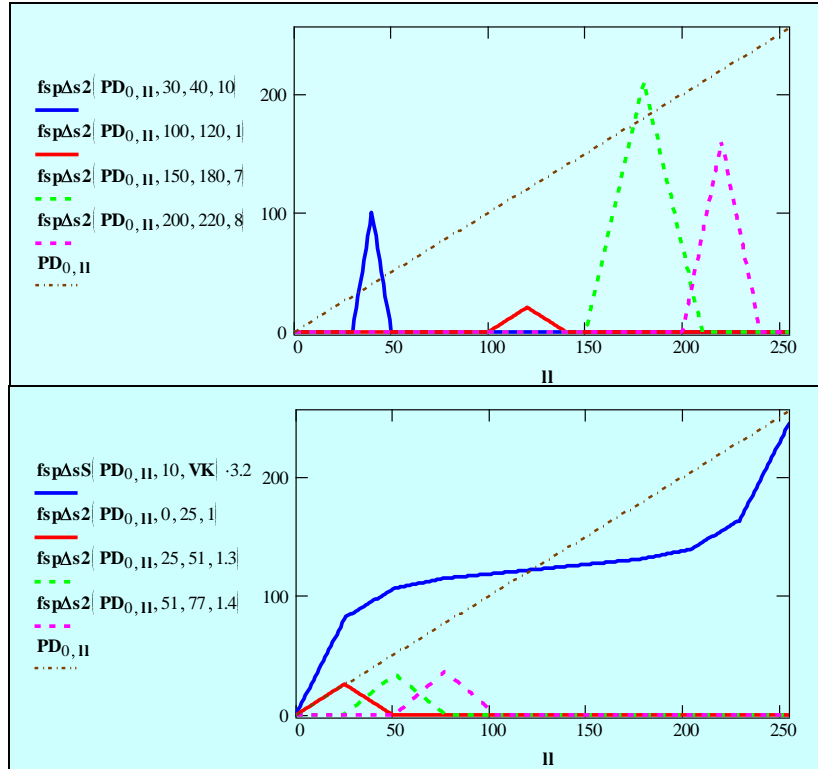

Fig. 2. Graphs of synthesized transformation functions

1.4.2 Design and simulation of array cells for image intensity transformation using OrCad PSpice

Let us first consider the design and simulation of a single base cell for the image intensity of an arbitrary transformation, using the example of a four-piece approximation by triangular signals according to formula (3). In Fig. 6 shows the scheme used for modeling, and Fig. 7 schematic of the basic sub-node. To form four triangular signals from the input signal, we use four identical sub-nodes, each of which consists of 14 (13) transistors and an additional current mirror (2

transistors Q18 and Q19), and for propagation of the input photocurrent and threshold levels, the auxiliary circuit consists of 17 (14) transistors.

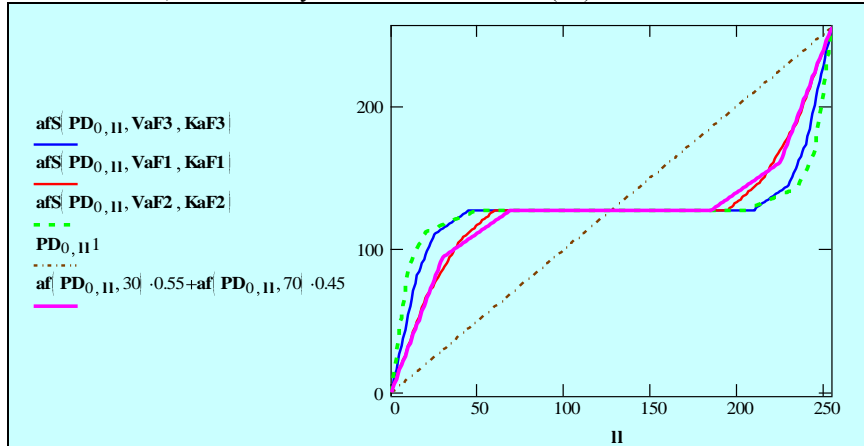

Fig. 3. Examples of synthesized transfer characteristics for autoequivalence functions

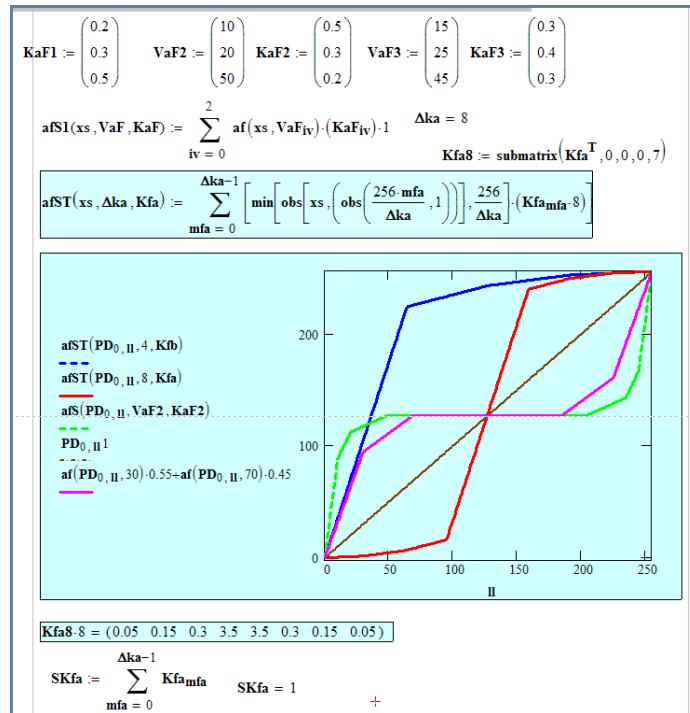

Fig. 4. Mathcad windows with the formulas and graphs of synthesized transformation functions

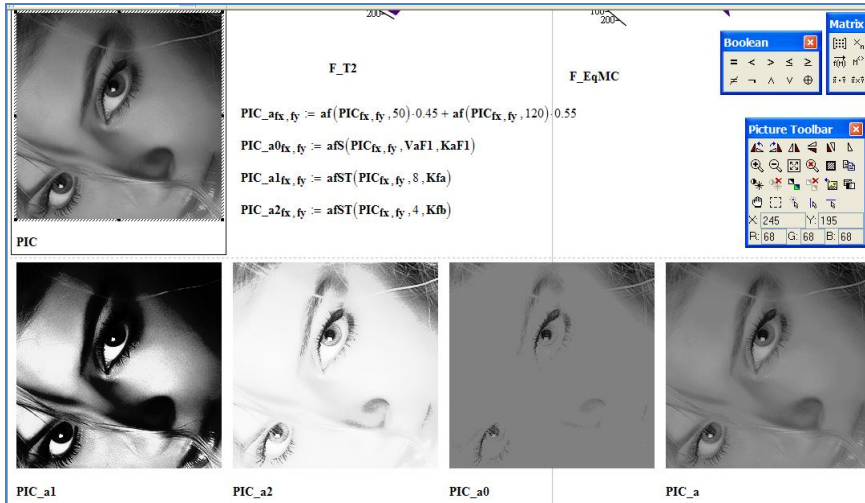

Fig. 5. Mathcad windows on which the formulas and results image intensity transformation are shown, where in 2D from left to right: input image PIC, the computed auto-equivalence functions, non-linear (after activation) output images (bottom row).

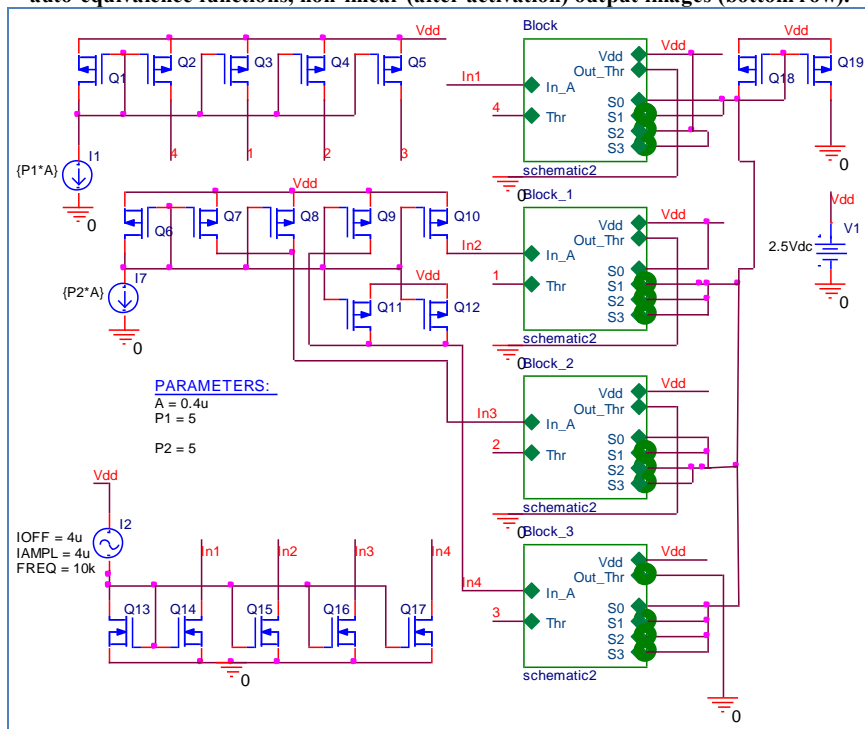

Fig. 6. Circuit for simulation of nonlinear converter cell on the base of four piece-linear approximation and four base sub-nodes

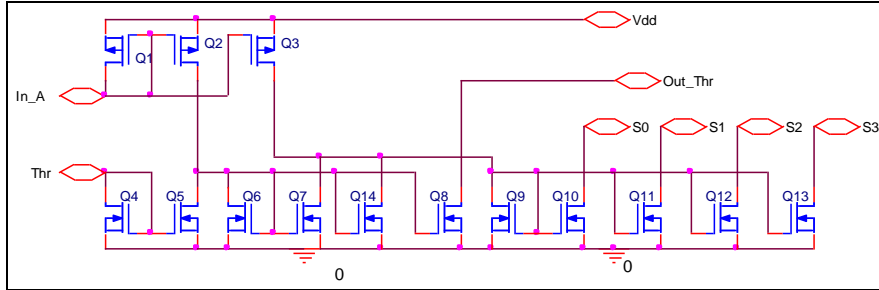

Fig. 7. Circuit of base sub-node (schematic2) for four piece-linear approximations

The input photocurrent was simulated by a current generator I2. In general, the cell layout consisted of 68 transistors. In this scheme for simulation, we used four fixed different gain values for each triangular signal. To do this, the output signal of the sub-node was multiplied using the current multiplier mirror (CMM), and by fixing the output connections S0-S3 with the summing output current mirror or the power line, we chose the weights k_i . Thus, we modeled different transformation functions by choosing a set of coefficients k_i . The simulation results for various input signals are shown in Fig. 8.

Using a linearly increasing input signal (red solid line) and a conversion function, the form of which is shown in the green bold line in Fig. 8a, and auxiliary signals (shown in different colors), we obtained a nonlinear transformation similar to the ReLu function (with saturation). In Fig. 8b, the resultant signal (green bold line) is shown after a nonlinear conversion by means of this function of the input sinusoidal signal (shown in blue). The power consumption of the cell is $150\mu\text{W}$ at a supply voltage of 2.5V , $I_{\text{max}} = D = 8\mu\text{A}$, $N = 4$, $p = 2\mu\text{A}$, and the periods of the input signals are $200\mu\text{s}$ and $100\mu\text{s}$. To dynamically switch the view of the image pixel intensity conversion function, we use the current-controlled current amplifiers on current mirror multipliers (CCCA) with binary-weighted current outputs (Fig. 9). The general scheme of the cell realizing the dynamic intensity conversion with eight piecewise linear approximation is shown in Fig. 10. This circuit contains from 170 to 200 transistors, consists of eight basic nodes (A + CCCA). The Node A consists of 8 (7) transistors and generates a triangular signal from the input signal at a given threshold for each sub-band pD_i . The auxiliary circuits for generating upper sub-band levels and subtracting them from the input signals are shown to the left in Fig. 10 and can be implemented in different ways depending on the selected element base and approach. The processes of formation from the input signal of all auxiliary components, triangular waveforms, nonlinearly transformed output signal, and simulation results of this circuit for different modes are shown in Fig. 11-12. For a supply voltage of 2.5V , $I_{\text{max}} = D = 8\mu\text{A}$, $N = 8$, $p = 1\mu\text{A}$ and the period of the input linearly increasing-decreasing triangular signal equal to $1000\mu\text{s}$.

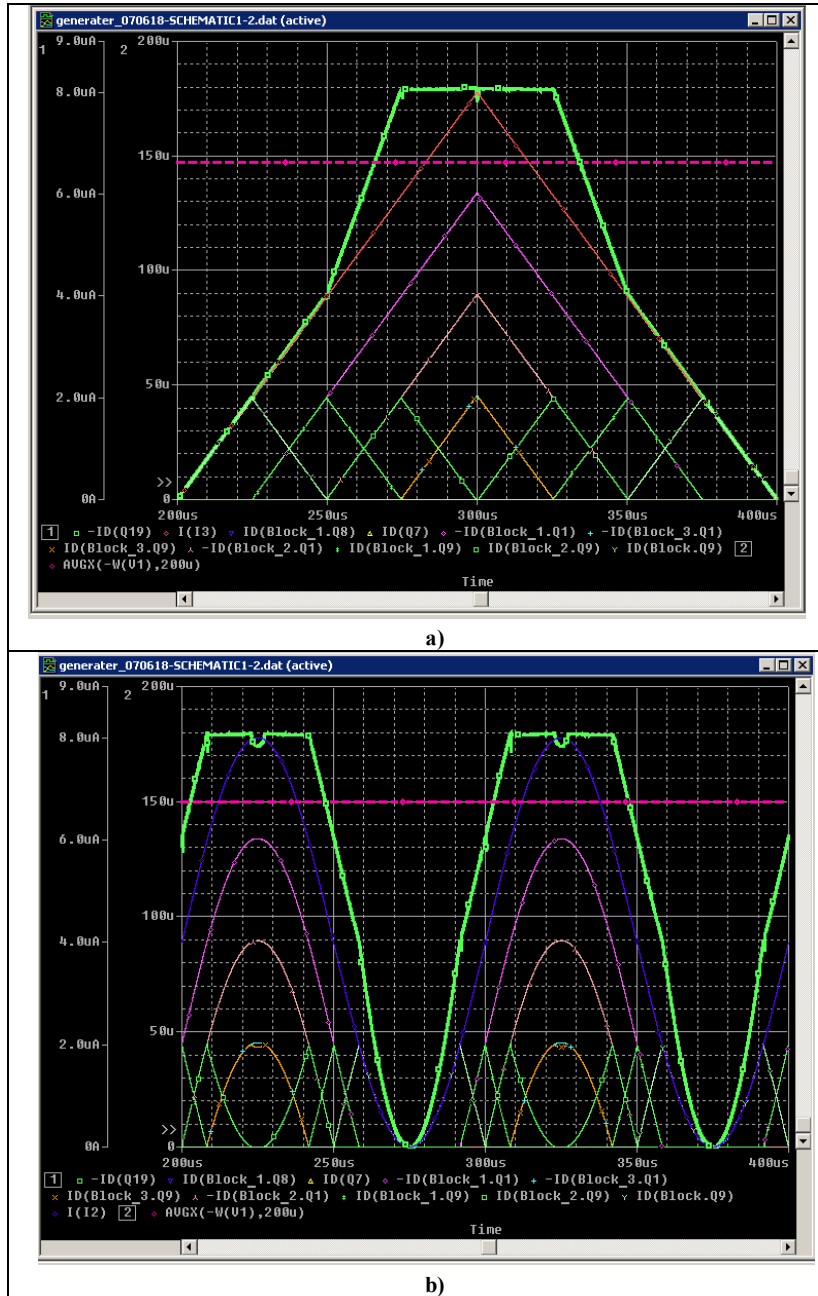

Fig. 8. Simulation result for the circuit in Fig. 6 for input linear rising signal (a) and for input sinusoidal signal (b)

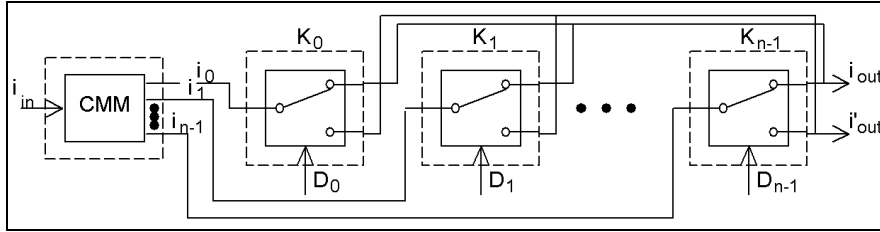

Fig. 9. Code controlled current amplifier (CCCA) that consists of current mirror with multiplication (CMM) and set of n keys (K)

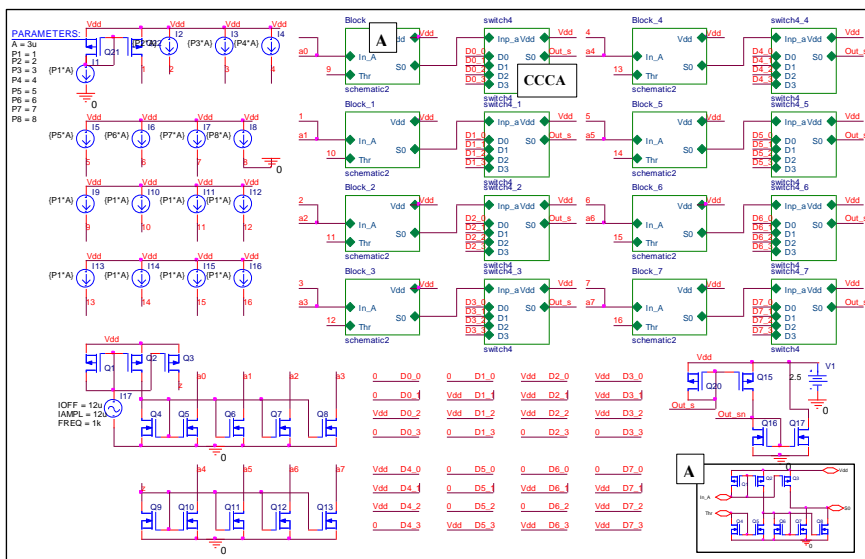

Fig. 10. Circuit for simulation of nonlinear converter cell on the base of eight piece-linear approximation and eight base sub-nodes

Removing only one transistor in the nodes A of the circuit in Fig. 10 allows it to modify and implement on its basis tunable nonlinear transformations in accordance with the formula 1, and not 3, that is, with the help of s_i , but not t_i .

The results of modeling such a conversion scheme with the composition of the basic step signals s_i are shown in Fig. 13 - 15, and in Fig. 14, 15 for the case of four levels approximation, and in Fig. 13 for eight levels approximation. The results confirm the possibility of synthesizing converter cells with specified or required accuracy characteristics of the transformation laws and, in particular, auto-equivalence functions, the microvolt level of power consumed by them, high speed (microseconds and less). For the simplest and approximate approximation functions, but often quite sufficient for the selection of the winning function by the activation function, the cell circuits consist of only 17-20 transistors, have a very high speed ($T = 0.25\mu s$), a small power consumption (less than 100 microwatts). The results of simulating such simple (3-4 piecewise approximation) cells (see

Fig. 16) separately and in the composition with nodes for input operators, and in small-sized networks of Eq equivalents are presented in section 1.4.3 and are shown in Fig. 17, 18. The analysis of the obtained results confirms the correctness of the chosen concept and the possibility of creating CLCs for image intensity transformation and MIMO structures on their basis, as hardware accelerators for compact high-performance systems of machine vision, CNN and self-learning biologically inspired devices.

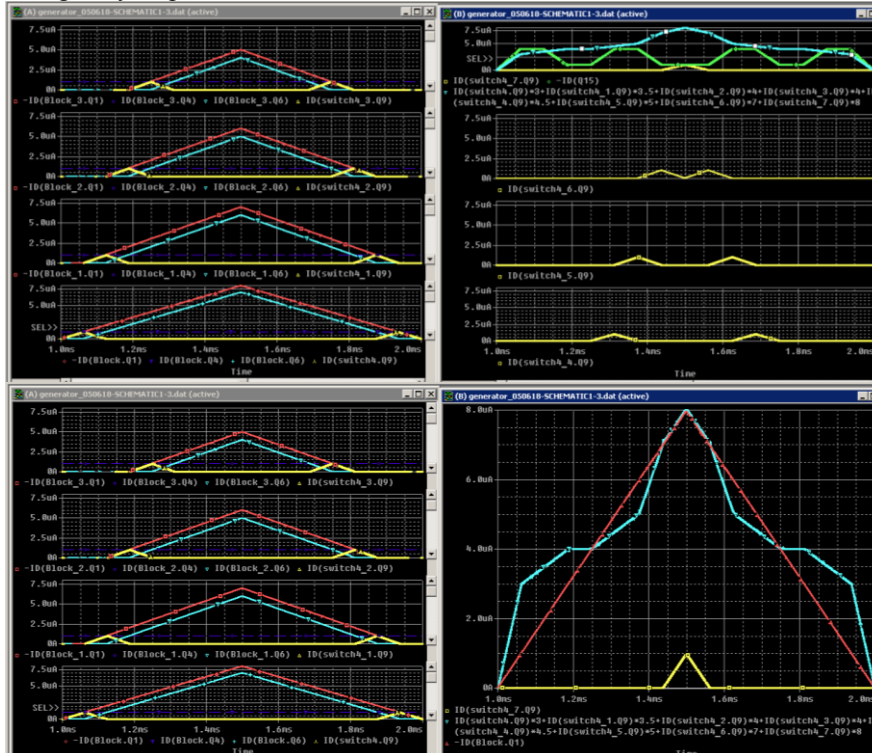

Fig. 11. Simulation result for 8 sub-nodes circuit (Fig. 10): up left - formation of triangle signals for linear rising input signal (red line), output signal (yellow line) (the first four signals); up right - formation of triangle signals (red line), output signal (yellow line) (the second 4 signals) and 2 outputs for 2 characteristics (blue and green lines); down right - input signal (red line), output signal (blue line)

1.4.3 Simulation of non-linear transformation in analog 64-input and 81-input neuron-equivalentor

For simulation of non-linear transformation in analog 64-input and 81-input neuron-equivalentor [66], we used a node whose circuit is shown in Fig. 16, which forms the activation function (autoequivalence) in the form of a piecewise linear approximation. Simulating results of such 64 input NE with nonlinear conversion

of the output signal-response for linearly rising (falling) currents with a period $T = 2.5\mu\text{s}$ are shown in Fig. 17, 18. In the same place, the results of modeling the formation processes of linear and nonlinear normalized neq are shown. Comparing two vectors with current signals, the 64-input neuron-equivalent has a total power consumption of approximately 2-3mW at a low supply voltage, contains less than 1000 CMOS transistors, provides good temporal characteristics. The circuit performs summation, limited subtraction, and multiplication of analog currents on current mirrors.

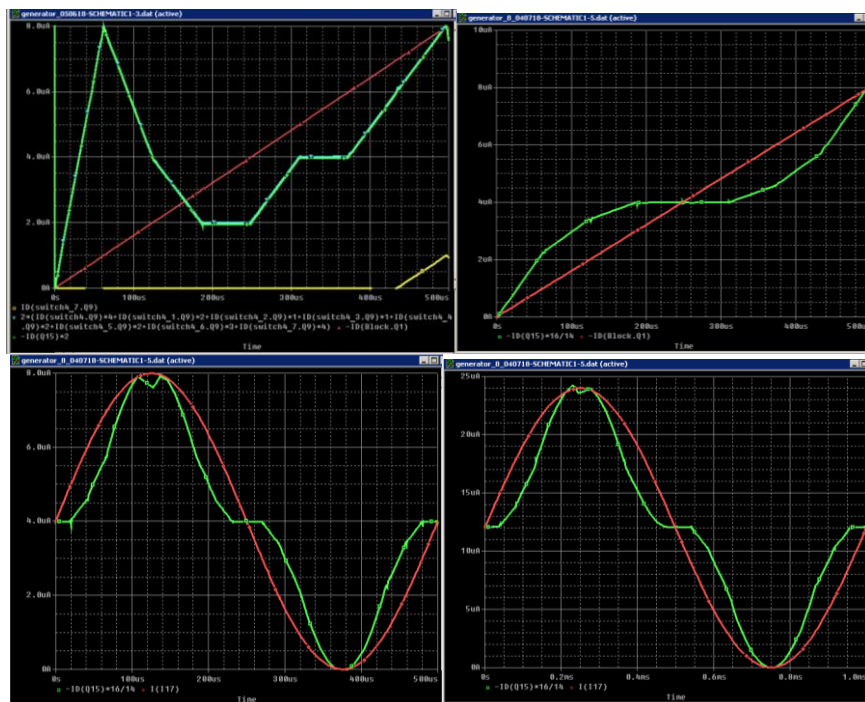

Fig. 12. Simulation result for 8 sub-nodes circuit (Fig. 10): up left - for linear rising input signal (red), output signal (green) and corresponds to N-shape transfer characteristic; up right - for linear rising input (red), output signal (green) and corresponds to the auto-equivalence transfer characteristic; down left and right - for sinusoidal input signal (red), output signal (green) and corresponds to the auto-equivalence transfer characteristic for input current range $0 \div 8\mu\text{A}$ and period $500\mu\text{s}$ (down left graph), $0 \div 24\mu\text{A}$ and 1ms (down right graph)

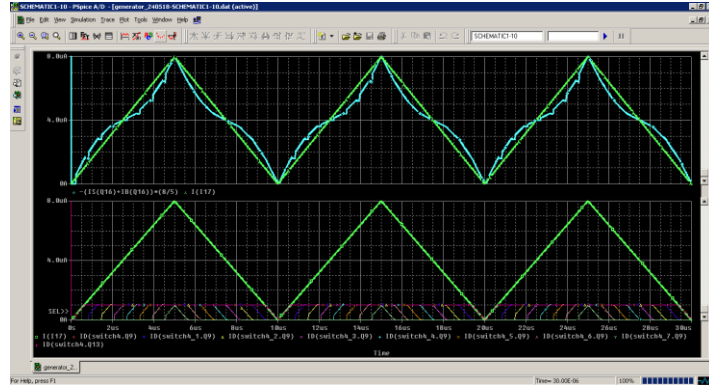

Fig. 13. Simulation result for circuit with step signals and eight levels approximation of input current signal: input signal (green line); output signal (blue line), other signals (color lines)

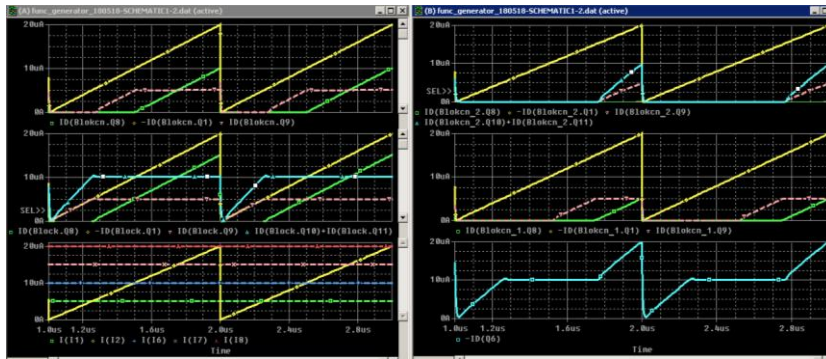
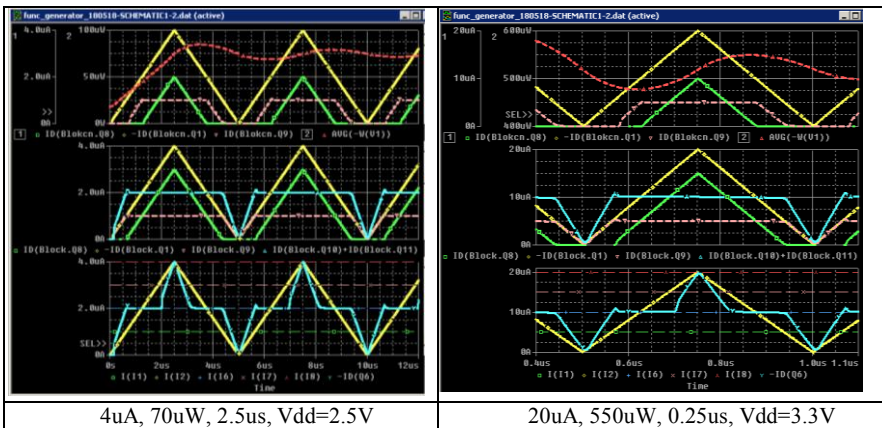

Fig. 14. Simulation result for four levels approximation, the realized non-linear transformation is the normalized auto-equivalence function for self-learning convolutional networks ($I_{max}=20\mu A$, $T=1\mu s$)



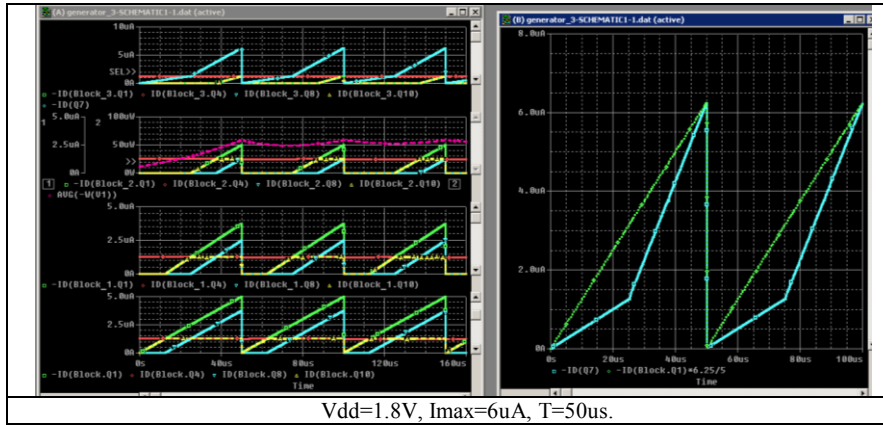

Fig. 15. Simulation result for four levels approximation, the realized non-linear transformation is the normalized auto-equivalence function for self-learning convolutional networks (for different input currents and transformation periods): input signal – yellow line, output signal – blue line, power consumption – red line

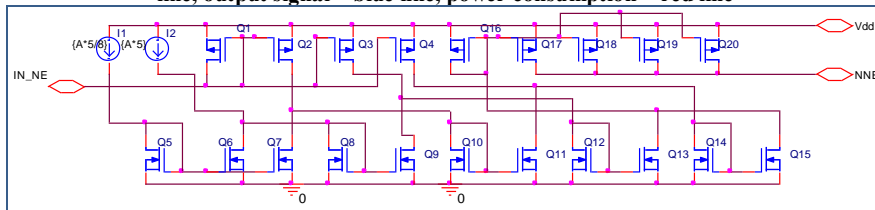

Fig. 16. Activation function circuit on current mirrors

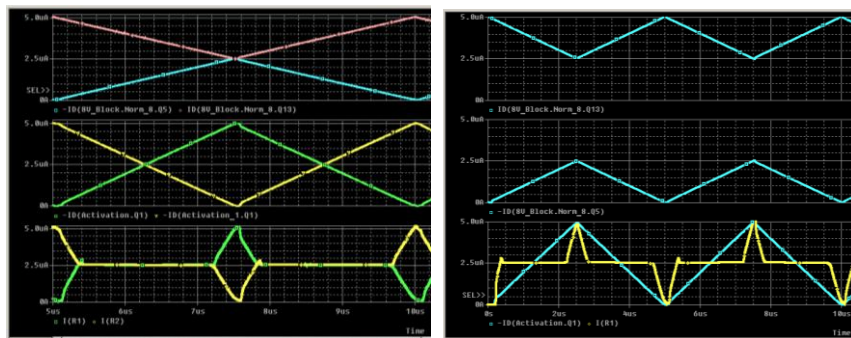

Fig. 17. The results of modeling the 64-input Eq for current $I_{max}=5\mu A$, and a linearly rising (falling) currents with a period $T=2.5\mu s$. On the left two upper signals (pink - maximum, blue - minimum of two input currents), green - equivalent signal, yellow - nonequivalence, below the signals after their nonlinear conversion; on the right, the two upper signals are the maximum and minimum, the lower the blue is the normalized equivalence, the yellow is the nonlinear normalized equivalence.

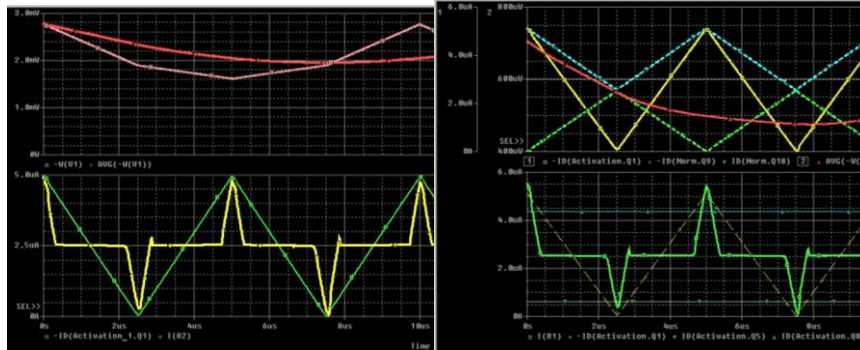

Fig. 18. The results of modeling the 64-input Eq for current $I_{max} = 5\mu A$, and a linearly rising (falling) currents with a period $T=2.5\mu s$. On the left: the results of modeling the processes of formation of linear (green) and nonlinear normalized neqs (yellow), on the upper graph the peak and average consumption powers are showed . On the right: the results of modeling the processes of formation of linear (yellow on the upper trace) and nonlinear normalized neqs (green on the bottom trace), red line shows the power of consumption. Blue - maximum of two signals, green - minimum of two signals for $V = 3.3V$

2 CONTINUOUS-LOGIC (CL) TRANSFORMATION AND THE EQUIVALENTLY CL ADC

2.1 Basic theoretical foundations, equivalence models and their modification for SMC_CL_ADC

These converters significantly reduce (or even eliminate) the error of digitization (quantization) inherent in the classical ADC. The CL - transformations are given in [30, 45, 51], in which the transformation CL functions (CLF) are defined and it is shown that the operation of min, max of continuous logic are the basic operations of the functions. Use of operators of hybrid logic for formation of CLF it is possible: $D_1[P \ x1, x2] = \max \ x_1, x_2$, $D_2[P \ x1, x2] = \min \ x_1, x_2$, where P and D are respectively threshold and non-threshold operators, which are implemented in various ways. In many models of neural networks for image recognition, especially many graded ones, it is desirable to have binary bit-plane images that encode the image matrix in Gray codes [41]. In addition, in a number of works [32–35, 40, 45, 46] it was shown that some operations of continuous logic, such as equivalence and nonequivalence, and their generalized family, provide a number of advantages in the so-called “equivalence paradigm”. These scalar operations of equivalence $eq(x,y)$ and nonequivalence $neq(x,y)$ for $x, y \in [0,1]$ are defined in papers [32, 33], namely:

$$\begin{aligned}
eq(x, y) &= x \wedge y + \bar{x} \wedge \bar{y} = \min(x, y) + \min((1-x), (1-y)) = 1 - |x - y|, \\
neq(x, y) &= |x - y| = 1 - eq(x, y) = \max(x, y) + \min(x, y) = \\
&= \max(\bar{x}, \bar{y}) - \min(\bar{x}, \bar{y}) = (x \dot{-} y) + (y \dot{-} x),
\end{aligned}$$

where $(\dot{-})$ - is the limited difference operation. If we consider it for $y = 1 - x = \bar{x}$, these functions are transformed to:

$$\begin{aligned}
eq(x, \bar{x}) &= 2(x \wedge \bar{x}) = 2 \min(x, \bar{x}), \\
neq(x, \bar{x}) &= \max(x, \bar{x}) - \min(x, \bar{x}) = 1 - 2 \min(x, \bar{x}),
\end{aligned}$$

as it has been shown in work [45], these functions can be successfully used in the CL ADC. For the formation of binary bit planes that correspond to the categories of images coded in the Gray code, we used for each pixel an iterative procedure over the matrices of equivalence and nonequivalence obtained in the previous stages: $eq_{i+1}(eq_i(\dots), neq_i(\dots))$ and $neq_{i+1}(eq_i(\dots), neq_i(\dots))$. It is easy to see that the division of the segment $[0, 1]$ into $2^n = N$ subranges, sets each of them a set, a vector of signs, which corresponds to the Gray code measured by the scalar size x . Thus, positional digit d_{n-i} of the code is defined as

$$d_{n-i}(eq_{i-1}, neq_{i-1}) = 1, \text{ if } eq_{i-1} > neq_{i-1}, 0, \text{ if else } ,$$

where $i \in 1 \dots n$, and $eq_0 = x$, $neq_0 = \bar{x}$. From this it is obvious that in order to realize the ADC for optical signals, we needed to synthesize BC CLs that implement the required operations eq_i , neq_i and the threshold operators. We called such ADCs equivalent to continuously-logical, complementary-dual ones, since the signals x and \bar{x} in them are complementary, and the CL functions are equivalent (nonequivalent), that is, equivalently CL ADC [45]. Since these ADCs were implemented on current mirrors (CM), and the input signals of the ADC are currents, we will designate such an ADC as an ADC CM [30]. In this work as transformation CLFs we use the following functions:

$$\begin{aligned}
eq_{i+1} \quad eq_i, D/2 &= 2 \quad eq_i \dot{-} 2 \quad eq_i \dot{-} D/2 \quad \text{or} \\
neq_{i+1} \quad neq_i, D/2 &= 2|neq_i - D/2|,
\end{aligned}$$

where $eq_0 = x$, $neq_0 = \bar{x}$, which allow us to work not with two signals, but with one signal, thereby simplifying the implementation of the cells. Structure of SMC CL ADC for IP is shown in Fig. 19.

2.2 Design of CL ADC CM-6(8) (G) -iv (the iteration variant) based on DC-(G) (with Gray code)

Fig. 20 shows a circuit of the one channel of SMC_ ADC. The structure is shown in Fig. 20a, and the base cell in Fig. 20b. The circuit consists of a select and hold device (SHD), a single digital-analog DC- (G) cell (block A), and additional elements (block B). The input analog current signal to be converted is recorded in

the SHD and then transmitted to the analog DC- (G), which will generate the next digital bit of the output code and the CL function.

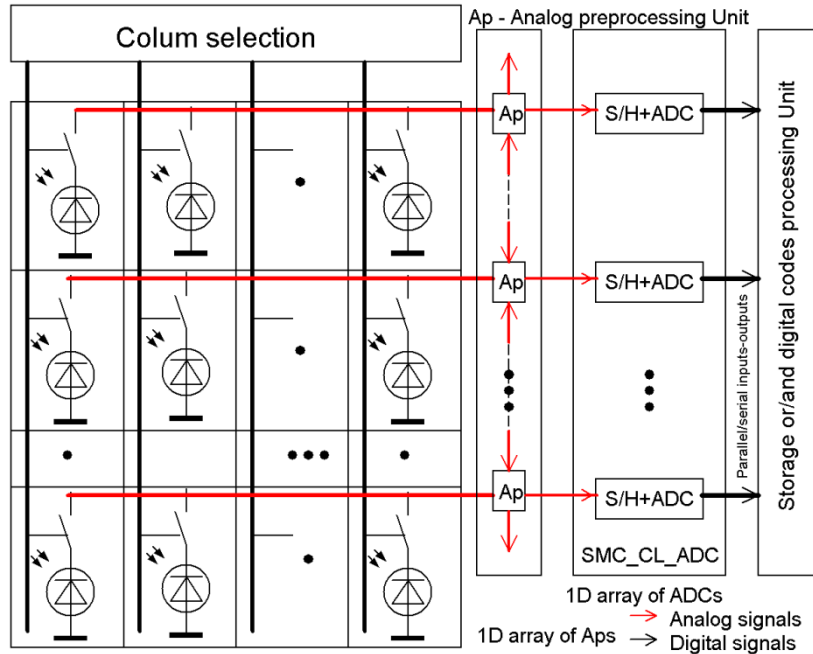
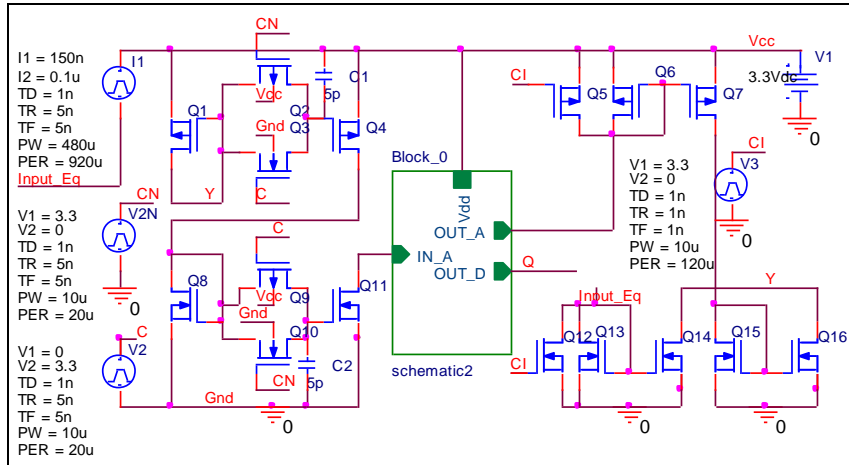

Fig. 19. Structure of 2D image sensor with 1D array of CL_ADC and storage or/and digital codes processing unit

This function is fed back to the SHD to form the next consecutive bits. The device selection and hold (SHD) consists of 18 transistors. DC - (G) consists of 15 or 17 transistors and a reference current generator. Since the circuit of one channel consists of only 33 (35) transistors, this makes it promising for multisensory systems. The DC converts the input analog signal to another output current signal, using CLF (section 2.1) over current signals and simultaneously compares it with the threshold current. The advantage of such continuous-logical transformations is that the form of such transformations can be very diverse and the operations of continuous logic used for such transformations themselves are also numerous.

Thus, there is a wide choice for searching and optimizing such cells taking into account the required goal. To minimize the aparata costs, cells can be very simple and consist of 10 - 20 transistors. In addition, the use of other known, with improved dynamic and accurate indicators of current comparators [50-52], including floating gate, etc., significantly expands the range of application of such implementations of ADC, reduces power consumption to microwatts, or significantly expands the dynamic range of input signals and maximum conversion frequencies.



a) Functional diagram of CL ADC CM-6(8) (G) -iv);

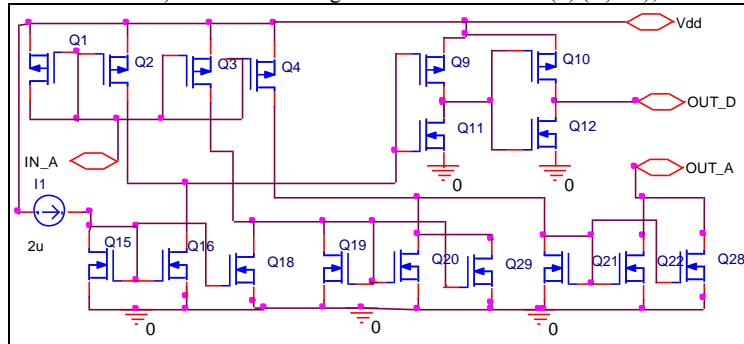

b) electrical circuit of block A;

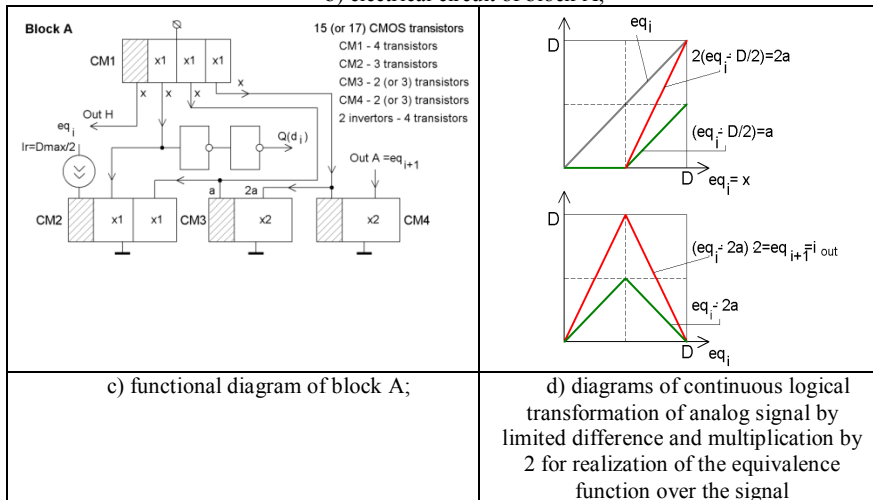
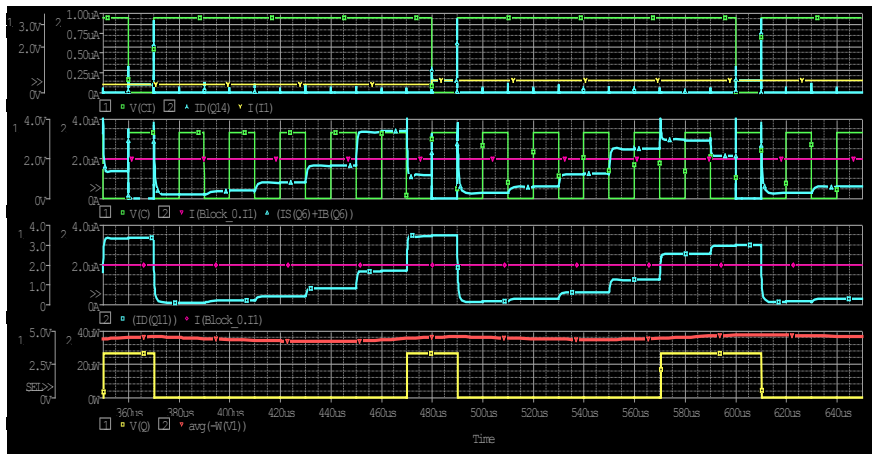

Fig. 20. Circuits of the one channel of multichannel CL ADC CM-6(8) (G) -iv with iteration transformation and base cell DC-(G)

The advantage of the structure with a serial output of the Gray code is that increasing the number of iterations increases the bit ADC with an unchanged structure. To convert a serial Gray code to a binary code, only one modulo adder and one D flip-flop are required. The Fig. 21, 22 show the results of simulation of one channel of six bits CL ADC CM-6 (G) -iv) with iteration transformation at linear-increasing input current signals. The total power consumption of this ADC-6 (8) (G) -iv did not exceed $70\mu\text{W}$ with a maximum input current of $4\mu\text{A}$ and a conversion period of $120\mu\text{S}$ ($6 \times 20\mu\text{S}$ for 6 bits) and a conversion period of $160\mu\text{S}$ ($8 \times 20\mu\text{S}$ for 8 bits). For operating modes with lower currents and $V_{\text{dd}} = 1.5 \div 1.8\text{V}$, the power consumption of ADC-6 (8) (G) -iv can be reduced to $10 \div 15\mu\text{W}$.

The drawback of our earlier works is the lack of research on the ultimate capabilities of such structures and their precision characteristics. Therefore, in this paper, we pre-observed such a structure in the formation of eight digit code, determined the possibility of operation with very small input currents ($10\text{nA} \div 1\mu\text{A}$), and adding to the structure of the DAC and converters from the Gray code to the binary code (see Fig. 23), determined the magnitude of ADC errors and its accuracy characteristics for different modes. By reducing the requirements for high-speed, the proposed diagram allows using analog-to-digital conversions for smaller amplitude input currents, and the power consumption of the such single ADC channel can be less than $50\mu\text{W}$ with $D_{\text{max}} = 1\mu\text{A}$. All the circuits are modeled on 1.5micron CMOS transistors. Simulation of analog-to-digital conversion errors is shown in Fig. 24. Simulation is performed for $D_{\text{max}} = 4\mu\text{A}$, 6-bit ADC, conversion period $T = 120\mu\text{s}$. Fig. 24 shows that the maximum error is about 1 least significant bit (LSB), and only for the maximum input current the error is about 2 LSB for the 8-bit ADC. Also, the simulation results showed that when reducing the conversion time to $10 \div 20\mu\text{s}$, the errors will be the same.

In Fig. 23 functional diagram of CL ADC CM-(8) (G) -iv) with Gray-to-binary code transformation and serial/parallel outputs with code converter and DAC for errors calculation are shown. Actually the ADC itself, from which 1D or 2D arrays will be done for sensors or image processors, in contrast to the circuit in Fig. 20 may additionally comprise some digital elements, for example, a logic element and a trigger or register. This depends on the possible modes and requirements regarding the formats of output and storage of code arrays. Therefore, in Fig. 23, these additional optional units are marked with a dash-dotted line. And to test the accuracy and timing characteristics in the dynamics, we used two registers and DAC. The results of modeling this circuit with OrCAD are partially shown in Fig. 24 and confirm the correct operation and analog-to-digital and code conversion, both when linearly increasing (decreasing) and sinusoidal current signals are applied to the ADC input. They show that for the 8-bit ADC, even in high-speed (I_{max} to $16 \div 24\mu\text{A}$) and low-voltage low-frequency energy-efficient modes (with I_{max} , namely $1\mu\text{A}$, $4\mu\text{A}$), the maximum error does not exceed $4 \div 5$ quantization quanta, and the average error does not exceed 2 LSB.



a)

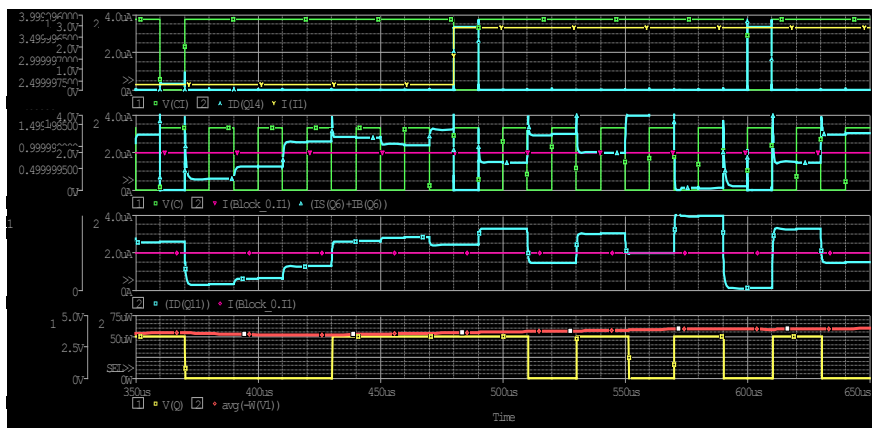

b)

Fig. 21. a) Simulation result for two input currents 100nA and 150nA, corresponding output Gray codes {000001} and {000011}; the blue line in the third trace is output current of the block for six digits ADC, the violet line is the threshold current; the yellow line in the fourth trace is output voltage of the block that corresponds to output code (a time interval for the first code 370 μ s - 490 μ s (six digits by 20 μ s), a time interval for the second code 490 μ s - 610 μ s; the red line is the consumption power about 40 μ W;

b) Simulation result for two input currents and corresponding output Gray codes {000111} and {010101}; the consumption power is about 40 μ W

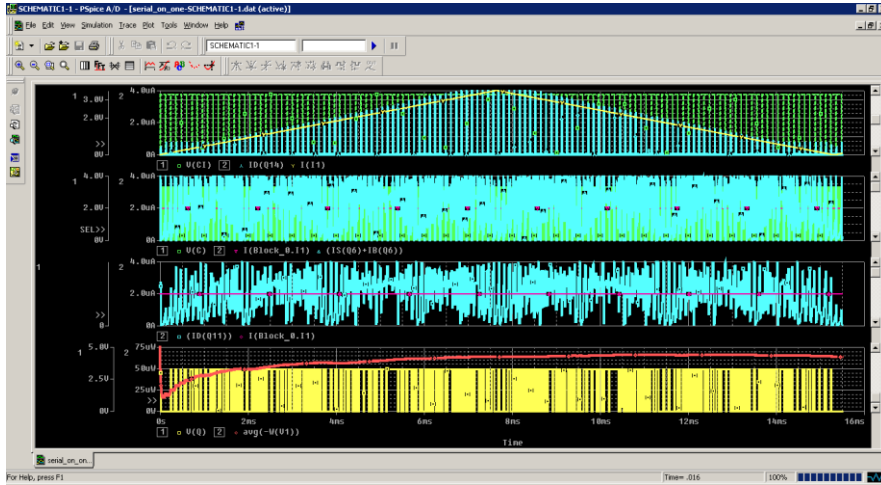

a)



b)

Fig. 22. Simulation results of the six digit ADC for a triangular current signal (the yellow line in the first trace): a) the whole time interval; b) for five time intervals with decreasing input current and corresponding output Gray code {100101}, {100100}, {100100}, {101101}, {101111} (the yellow line in the fourth trace), the red line is the consumption power about 70μW

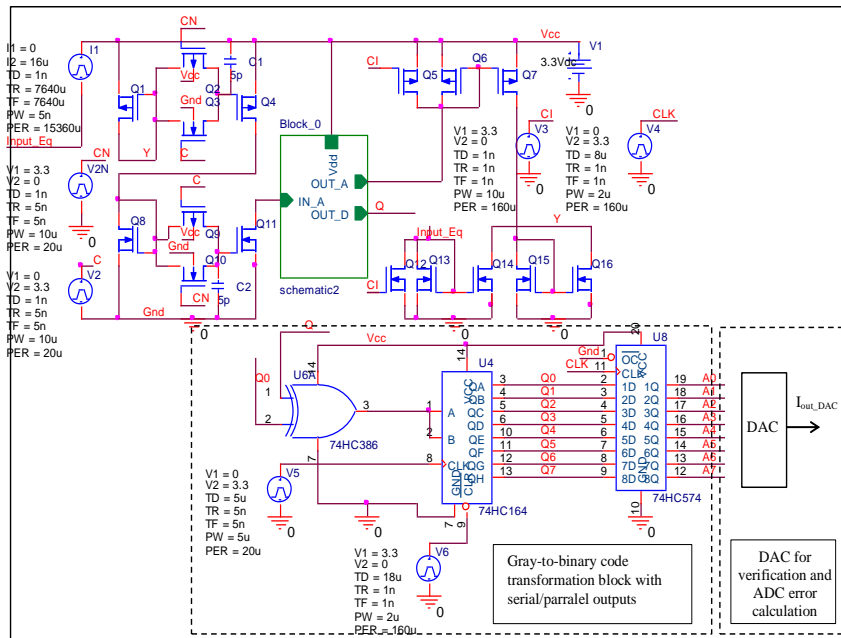
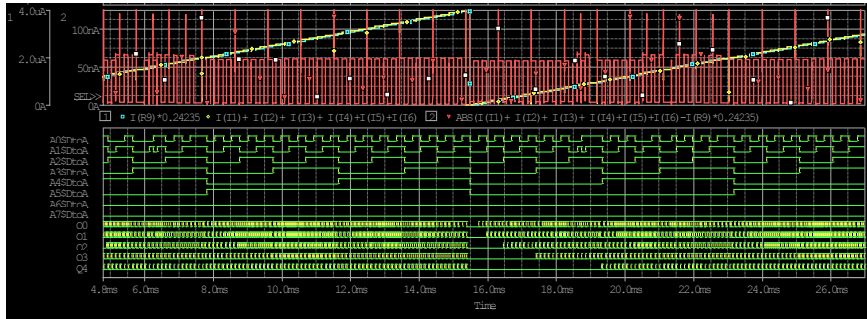

Fig. 23. Functional diagram of CL ADC CM-(8) (G) -iv with Gray-to-binary code transformation and serial/parallel outputs with code converter and DAC for errors calculation.

2.3 Simulating parallel-conveyor CL_ADC (P_C) based on eight 8-DC- (G) with parallel-serial output

The block diagram of parallel-conveyor CL_ADC (P_C) based on 8-DC- (G) (with Gray code) with a parallel-serial output is shown in Fig. 25. The simulation results with PSpice OrCAD are shown in Fig.26. Researches have shown, that in such CL_ADC (P_C) 6 (8)-DC-(G) at change I_{max} from $16\mu A$ to $24\mu A$ the consumption power at 3,3 V was from $1\mu W$ to $2\mu W$ (6 bits) and $3\mu W$ (8 bits). The conversion frequencies in the experiments were for these currents: 32, 40, 50 MHz for $16\mu A$ and 64 MHz for $24\mu A$ and $40\mu A$.



a) The blue line is the DAC output current, yellow line is the 8 bit ADC input current, the red line is the ADC current error (<70nA); Q0..Q7 – output digital signals of the shift register, A0-A7 – output digital signals of binary parallel code at the latch register

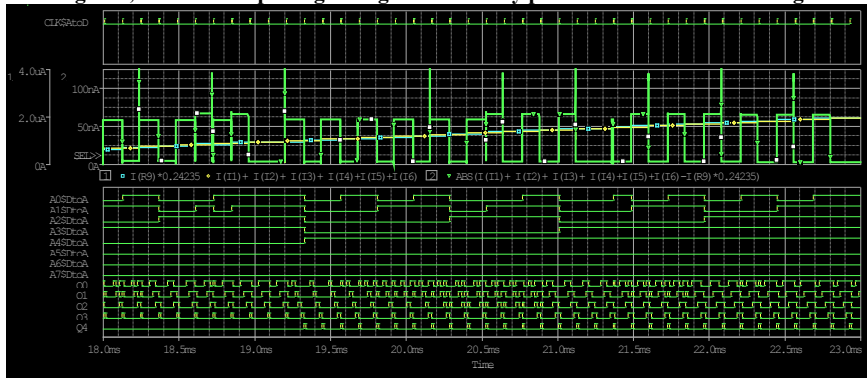

b) the blue line is the DAC output current, the yellow line is the ADC input current, the green line is the ADC current error (<70nA), A0-A7 – output digital signals of binary parallel code, Q0..Q4 – part of output digital signals of the shift register

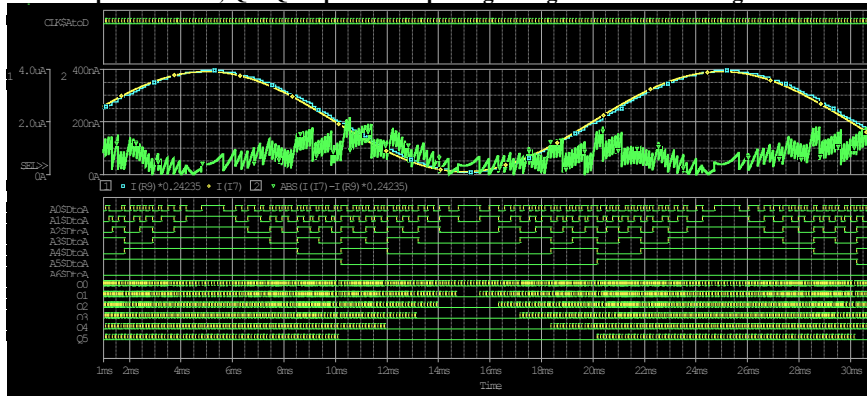

c) the blue line is the DAC output current, the yellow line is the ADC input current, the green line is the ADC current error (<200nA), A0-A6 – part outputs digital signals of 8 binary parallel code, Q0..Q5 – part of outputs 8 digital signals of the shift register

Fig. 24. Simulation results of the 8 bit ADC with Gray-to-binary code transformation and serial/parallel outputs

They correspond to different modes: different I_{max} , namely $1\mu A$, $4\mu A$, $16\mu A$, $24\mu A$, $40\mu A$; various $1,5V$, $1,8V$, $2,5V$, $3,3V$; various transformation periods T ($0,02\mu S$, $0,025\mu S$, $1\mu S$, $20\mu S$, $100\mu S$) etc. These researches show, that power consumption actually ADC for the specified values I_{max} (equal $1\mu A$ and $1,8V$, $64nA$ and $1,5V$) makes accordingly $40\mu W$ and $2\mu W$, the quantization step is $15,625nA$ for $I_{max}=4\mu A$ and $62.5nA$ for $I_{max}=16\mu A$, and quantization frequency $40MHz$.

The essence of analog preprocessing is to find the function from the signals of several adjacent channels for different 1D, 2D windows. In this case, the 1D window is a size of 3 (may be 5, 7, 9 etc.), and the processing type is the function of finding the average of the three signals. As a function, any continuous logic functions of the type max, min, described in Section 2.1 and in paper [41], can be used.

The analog preprocessing unit (see Fig. 19) consists of 4 (6) CMOS transistors (see Fig. 27) in this case. For functions min, max and etc. the Ap-unit consists of about 10 – 20 CMOS transistors. The consumption power of one channel 8 bit ADC + Ap-unit is less $250\mu W$. Simulation results of analog signals preprocessing (selecting average signal out of three neighbor channels signals) for different input signals (linearly increasing (decreasing) and sinusoidal signals) are shown in Fig 28.

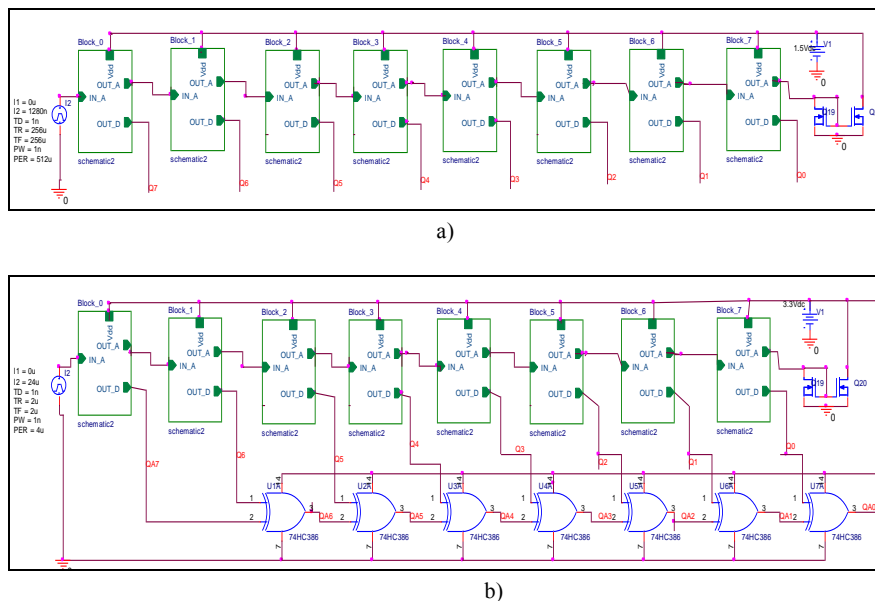
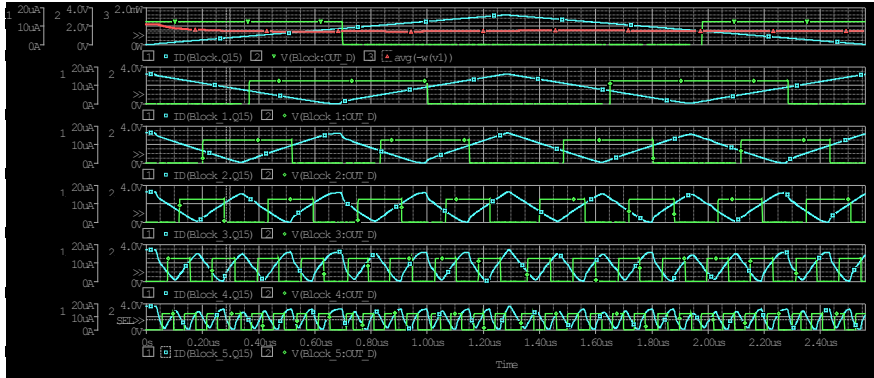
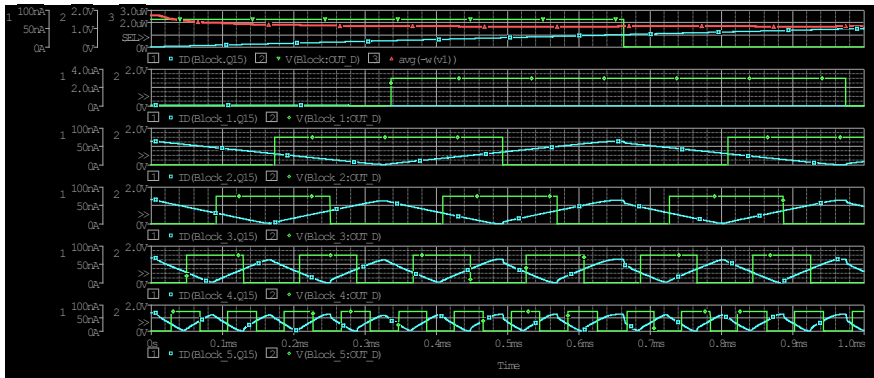

Fig. 25. Structure of 8 bit ADC: a) with Gray code parallel outputs (Q0-Q7); b) with Gray-to-binary code transformation and parallel outputs (QA0-QA7)



a) Time diagrams of signals of digit converting cells of 6 bit CL_ADC for mode: converting frequency $F= 50\text{MHz}$, input current $I_{\text{max}}=16\mu\text{A}$, $V_{\text{dd}}=3.3\text{V}$, consumption power $P\approx 1\text{mW}$



b) Time diagrams of signals of digit converting cells of 6 bit CL_ADC for mode: converting frequency $F= 50\text{kHz}$, input current $I_{\text{max}}=64\text{nA}$, $V_{\text{dd}}=1.5\text{V}$, consumption power $P\approx 2\mu\text{W}$

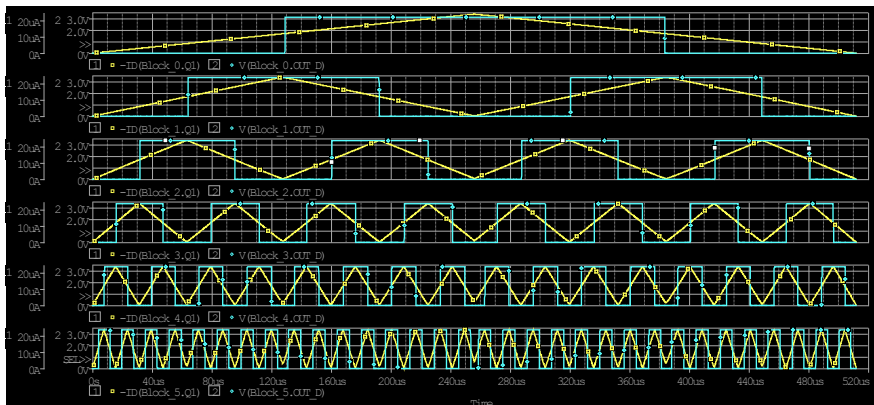

c) Time diagrams of signals of digit converting cells of 8 bit ADC (6 cells out of 8 are shown) for mode: converting frequency $F= 1\text{MHz}$, input current $I_{\text{max}}=24\mu\text{A}$, $V_{\text{dd}}=3.3\text{V}$

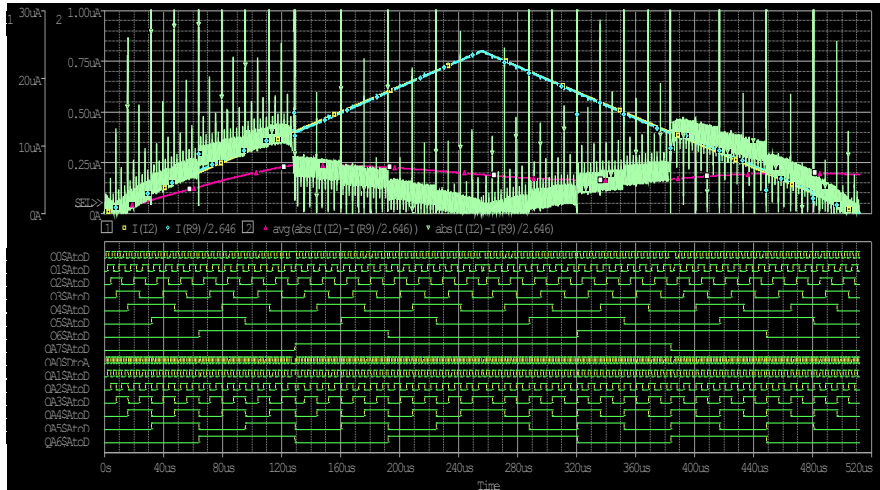

d) Time diagrams of 8 bit parallel CL_ADC signals by simulation for $I_{\text{input_max}}=24\mu\text{A}$, ADC conversion time is $1\mu\text{s}$; the blue line is the DAC output current, the yellow line is the ADC input current, the violet line is the average ADC current error ($<250\text{nA}$), the green line is the ADC current error; QA0-QA7 – output digital signals of binary parallel code, Q0..Q7 (Q7=QA7) – output digital signals of Gray parallel code

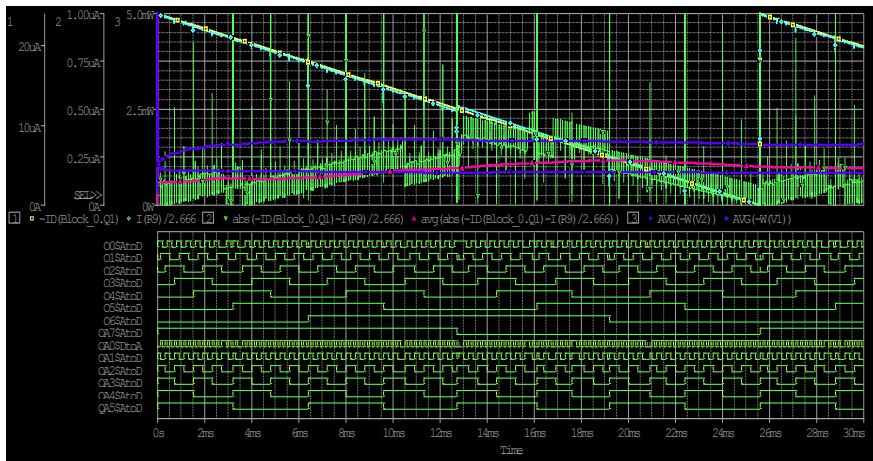

e) Time diagrams of 8 bit parallel CL_ADC signals by simulation for $I_{\text{input_max}}=24\mu\text{A}$; the blue line is the DAC output current, the yellow line is the ADC input current, the violet line is the average ADC current error ($<250\text{nA}$), the green line is the ADC current error, the blue line is the power consumption (3mW)

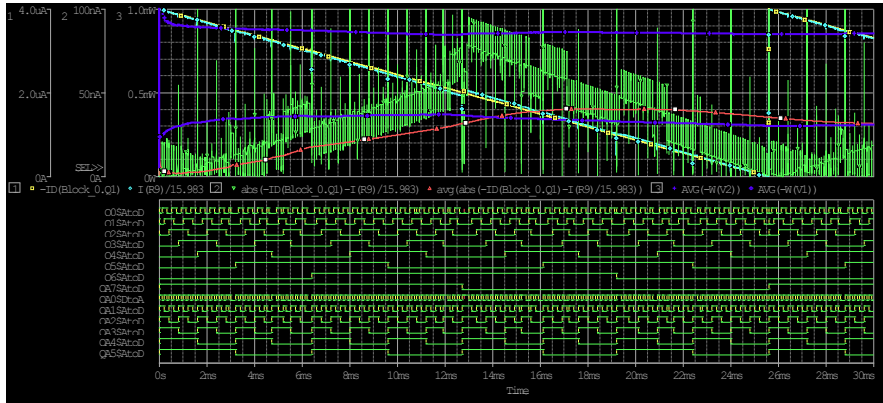

f) Time diagrams of 8 bit parallel CL_ADC signals by simulation for $I_{input_max}=4\mu A$, conversion frequency is 10kHz; the blue line is the DAC output current, the yellow line is the ADC input current, the violet line is the average ADC current error (<math>< 40\text{ nA}</math>), the green line is the ADC current error, the blue line is the power consumption (1.3mW)

Fig. 26. Structure of multichannel 8 bit ADC (1D array 8 bit CL_ADC) and simulations results.

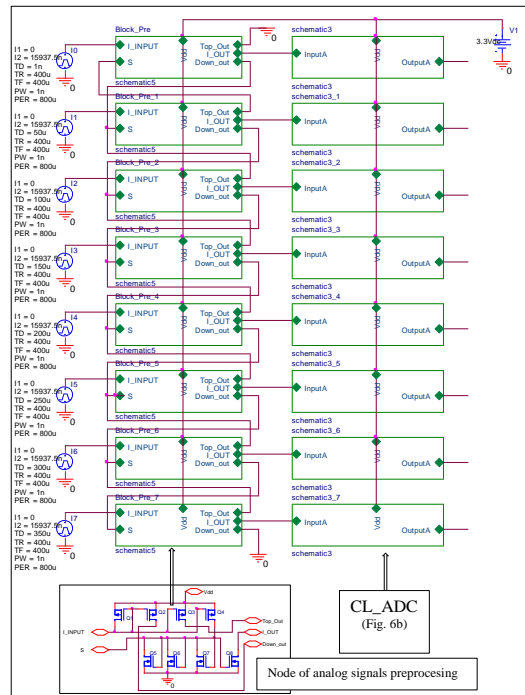
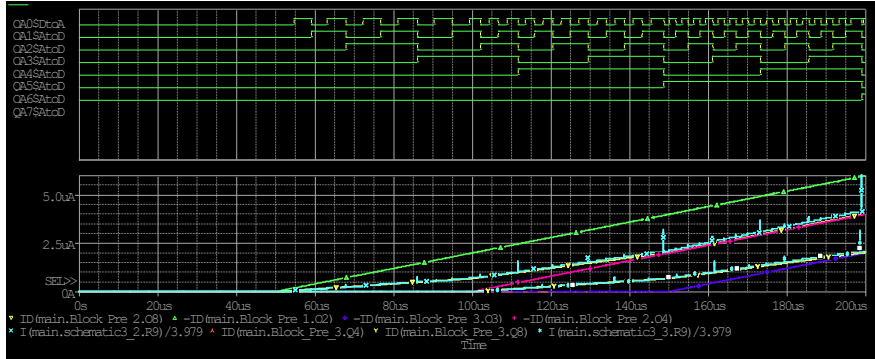
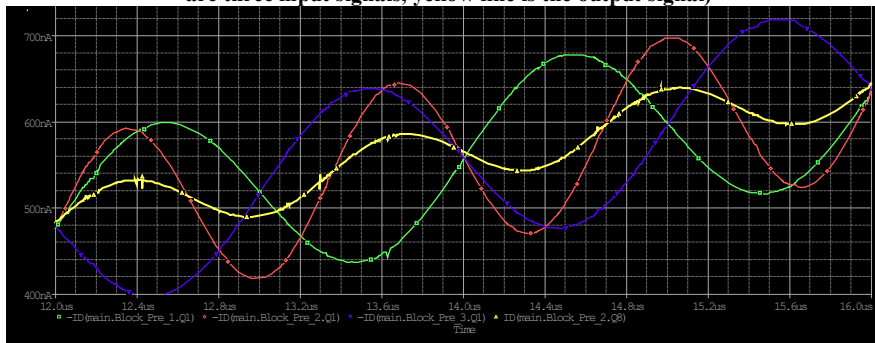

Fig. 27. Structure of multichannel 8 bit ADC (1D array 8 bit CL_ADC) with analog signals preprocessing



a) simulation results of analog signals preprocessing (selecting average signal out of three neighbor channels signals): green, blue, violet lines are three input signals, yellow line is the output signal)



b) simulation results of analog signals preprocessing (selecting average signal out of three neighbor channels signals): green, blue, red lines are three input signals, yellow line is the output signal)

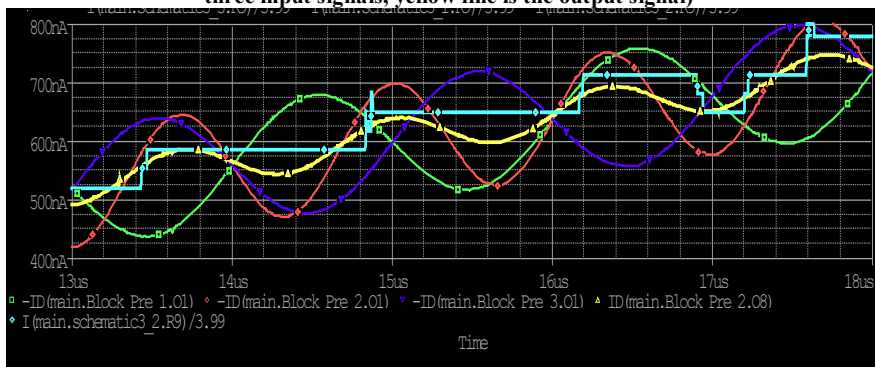

c) simulation results of analog signals preprocessing (selecting average signal out of three neighbor channels signals): green, blue, violet lines are three input signals, yellow line is the output signal), light blue is the DAC output signal

Fig. 28. Structure of multichannel 8 bit ADC (1D array 8 bit CL_ADC) with analog signals preprocessing

CONCLUSIONS

For the construction of mixed image processor (IP) and neural networks (NNs), and image intensity transformation, the fundamentals of continuous logic cell (CLC) design based on current mirrors (CM) with functions of preliminary analog processing are proposed. Several effective schemes have been developed and modeled of CLC and optoelectronic complement dual analog neuron-equivalentors as hardware accelerators SLECNS. The proposed **CLC** have a modular hierarchical construction principle and are easily scaled. Their main characteristics were measured. They have a low supply voltage of 1.8-3.3V, small power consumption of no more than 1mW, processing time-conversion 0.1-1 μ s, insignificant relative calculation errors (1-5%), can work in low-power modes (less than 100 μ W) and high-speed (1-2MHz) modes. The relative to the energy efficiency of CLC and equivalentors is estimated at a value of not less than 10^{12} an. op. / sec. per W and can be increased by an order. The correctness of the chosen concept is confirmed by the obtained results of the design and creation of neuron-equivalentors (**NEqs**) and MIMO structures based on them. Such neuron equivalentors can form the basis of promising self-learning biologically-inspired devices SLECNS and CNN, in which the number of such parallel-running **NEqs** is 1000. Thus, we have proposed implementation options for digital-analog cells (DC) and CL structures of the ADC CM. Such ADCs have simplicity and only one DC is required for the iteration type, supplemented by a sample and hold device. The advantage of the ADC is the ability to easily implement parallel code, as well as serial-parallel output code. Results of circuit simulation using OrCAD are shown. Such simple structure of CL ADC CM with low power consumption ≤ 3 mW and supply voltage 1.8 \div 3.3V, and at the same time with good dynamic characteristics (frequency of digitization even for 1,5 μ m CMOS-technologies is 40MHz, and can be increased up to 10 times) and accuracy (Δ quantization=15.6 \div 62.5nA for $I_{max}=4\div 16\mu$ A) characteristics are shown. Taking into account the sensitivity of modern photo detectors, the range of optical signals can be 1–200 μ W. For the ADC of iteration type one channel consists of one DC-(G) and SHD, and it has only 35 \div 40 CMOS transistors. Since such 1D, 2D arrays of serial ADCs are very perspective for sensors and IP. The general power consumption of one ADC, in this case, is only 50 \div 70 μ W, if the maximum input current is 4 μ A. For high performance and frequency of conversions, it is preferable to use the parallel-pipeline CL_ADC (P_C) scheme based on the set of 8-DC-(G) with parallel-serial outputs. The maximal error is about 1LSB, and only about 2 LSB for 8-bit CL ADC for the maximal input current. CL ADC CM with analog signals preprocessing opens new prospects for realization linear and matrix (with picture operands) micro photo-electronic structures which are necessary for neural networks, digital optoelectronic processors, neural-fuzzy controllers.

References

- [1] Krasilenko V. G., Aleksandr I. Nikolsky, Yuriy A. Bozniak, "Recognition algorithms of multilevel images of multi-character identification objects based on nonlinear equivalent metrics and analysis of experimental data," *Proceedings of SPIE Vol. 4731*, pp.154-163 (2002).
- [2] Krasilenko V. G., Alexandr I. Nikolsky, Yuriy A.Bozniak, "Recognition Algorithms of Images of Multi-Character Identification Objects Based in Nonlinear Equivalent Metrics and Analysis of Experimental Dat Using Designed Software," *Proceedings of Eleventh All-Ukrainian International Conference*, pp. 107-110 (2012)
- [3] Krasilenko V. G., Y.A. Boznyak, G.N. Berozov, "Modelling and comparative analysis of correlation and mutual alignment equivalent images," *Science and learning process: scientific and methodical. Proceedings Scientific Conference of the VSEI Entrepreneurship University "Ukraine"*, pp. 68-70 (2009).
- [4] Krasilenko, V. G., Magas, A. T., "Multiport optical associative memory based on matrix-matrix equivalentors," *Proceedings of SPIE Vol. 3055*, pp. 137 - 146 (1997).
- [5] Krasilenko, V. G, "Research and design of equivalence model of heteroassociative memory," *The Scientific session of MIFI-2010 Vol.2*, pp.83-90 (2010).
- [6] Krasilenko, V. G., Saletsky, F. M., Yatskovsky, V. I., Konate, K., "Continuous logic equivalence models of Hamming neural network architectures with adaptive-correlated weighting," *Proceedings of SPIE Vol. 3402*, pp. 398-408 (1998).
- [7] Krasilenko, V. G., Nikolsky, A. I., Yatskovskaya, R. A., Yatskovsky, V. I., "The concept models and implementations of multiport neural net associative memory for 2D patterns," *Proceedings of SPIE Vol. 8055, 80550T* (2011).
- [8] Krasilenko, V. G., Lazarev, A., Grabovlyak, S., "Design and simulation of a multiport neural network heteroassociative memory for optical pattern recognitions," *Proc. of SPIE Vol. 8398, 83980N-1* (2012).
- [9] Krasilenko V.G., Nikolsky, A. I., "Optical pattern recognition algorithms based on neural-logic equivalent models and demonstration of their prospects and possible implementations," *Proc. of SPIE Vol. 4387*, pp. 247-260 (2001).
- [10]Krasilenko, V. G., Kolesnitsky, O. K., & Boguhvalsky, A. K. "Application of non-linear correlation functions and equivalence models in advanced neuronets," *Proc. of SPIE Vol. 3317*, pp. 211-223 (1997).
- [11]Krasilenko V.G., Nikitovich D.V., "Experimental studies of spatially invariant equivalence models of associative and hetero-associative memory 2D images," *Systemy obrobky informaciji Kharkivskijy universytet Povitrjanykh Syl imeni Ivana Kozheduba Vol. 4* (120), pp. 113-120 (2014).
- [12]Krasilenko V. G. , Alexander A. Lazarev, Sveta K. Grabovlyak, Diana V. Nikitovich, "Using a multi-port architecture of neural-net associative memory based on the equivalency paradigm for parallel cluster image analysis and self-learning," *Proceedings of SPIE Vol. 8662, 86620S* (2013).
- [13]Krasilenko, V. G., Nikolsky, A. I., and Flavitskaya, J. A., "The Structures of Optical Neural Nets Based on New Matrix_Tensor Equivalently Models (MTEMs) and Results of Modeling," *Optical Memory and Neural Networks (Information Optics) Vol. 19* (1), 31–38 (2010).
- [14]Krasilenko V. G., Alexander A. Lazarev, Diana V. Nikitovich, "Experimental research of methods for clustering and selecting image fragments using spatial invariant equivalent models," *Proceedings of SPIE Vol. 9286, 928650* (2014).
- [15]Krasilenko V.G., Nikitovich D.V., "Researching of clustering methods for selecting and grouping similar patches using two-dimensional nonlinear space-invariant models and functions of normalized equivalence," *VII Ukrainian-Polish scientific and practical conference Electronics and information technologies (ELIT-2015)*. – Lviv: Ivan Franko National University of Lviv, pp. 129-134 (2015).

- [16]Krasilenko V.G., Nikitovich D.V., "Modeling combined with self-learning clustering method of image fragments in accordance with their structural and topological features," *Visnyk Khmeljnycykogho nacionaljnogho universytetu* Vol. 2, 165-170. (2014).
- [17]Krasilenko V.G., Nikitovich D.V., "Sumishhenyj z samonavchannjam metod klasteryzaciji fragmentiv zobrazhenj za jikh strukturno-topologichnymy oznakamy ta jogho modeljuvannja," *Pytannja prykladnoji matematyky i matematychnogho modeljuvannja*, pp. 167-176 (2014).
- [18]Y. LeCun and Y. Bengio. Convolutional networks for images, speech, and time-series. In M. A. Arbib, editor, *The Handbook of Brain Theory and Neural Networks*. MIT Press, 1995.
- [19]Y. Lecun, L. Bottou, Y. Bengio and P. Haffner, "Gradient-based learning applied to document recognition," in *Proceedings of the IEEE*, vol. 86, no. 11, pp. 2278-2324, Nov 1998. doi: 10.1109/5.726791
- [20]Alex Krizhevsky, Ilya Sutskever, and Geoffrey E. Hinton. ImageNet classification with deep convolutional neural networks. In *Proceedings of the 25th International Conference on Neural Information Processing Systems (NIPS'12)*, F. Pereira, C. J. C. Burges, L. Bottou, and K. Q. Weinberger (Eds.). Curran Associates Inc., USA, 1097-1105. 2012.
- [21]Shafiee et al., "ISAAC: A Convolutional Neural Network Accelerator with In-Situ Analog Arithmetic in Crossbars," *2016 ACM/IEEE 43rd Annual International Symposium on Computer Architecture (ISCA)*, Seoul, 2016, pp. 14-26. doi: 10.1109/ISCA.2016.12
- [22]Di Zang, Zhenliang Chai, Junqi Zhang, Dongdong Zhang, JiuJun Cheng, "Vehicle license plate recognition using visual attention model and deep learning," *Journal of Electronic Imaging* 24(3), 033001 (4 May 2015). <http://dx.doi.org/10.1117/1.JEI.24.3.033001>
- [23]Graham W. Taylor, Rob Fergus, Yann LeCun, and Christoph Bregler. 2010. Convolutional learning of spatio-temporal features. In *Proceedings of the 11th European conference on Computer vision: Part VI (ECCV'10)*, Kostas Daniilidis, Petros Maragos, and Nikos Paragios (Eds.). Springer-Verlag, Berlin, Heidelberg, 140-153.
- [24]Q. V. Le, W. Y. Zou, S. Y. Yeung and A. Y. Ng, "Learning hierarchical invariant spatio-temporal features for action recognition with independent subspace analysis," *CVPR 2011*, Providence, RI, 2011, pp. 3361-3368. doi: 10.1109/CVPR.2011.5995496
- [25]Krasilenko V.G., Lazarev A.A., Nikitovich D.V., "Modeling and possible implementation of self-learning equivalence-convolutional neural structures for auto-encoding-decoding and clusterization of images," *Proceedings of SPIE* Vol. 10453, 104532N (2017)
- [26]Krasilenko V.G., Lazarev A.A., Nikitovich D.V., "Modeling of biologically motivated self-learning equivalent-convolutional recurrent-multilayer neural structures (BLM_SL_EC_RMNS) for image fragments clustering and recognition," *Proc. SPIE 10609, MIPPR 2017: Pattern Recognition and Computer Vision, 106091D* (8 March 2018); doi: 10.1117/12.2285797; <https://doi.org/10.1117/12.2285797>
- [27] Fey, D., "Architecture and technologies for an optoelectronic VLSI," *Optic* 112(7), 274-282 (2001).
- [28] Lei Yi, Guangbao Shan, Song Liu, Chengmin Xie, High-performance processor design based on 3D on-chip cache, *Microprocessors and Microsystems*, Volume 47, 2016, Pages 486-490, ISSN 0141-9331, <http://dx.doi.org/10.1016/j.micpro.2016.07.009>.
- [29] Florian Maier-Flaig, Julia Rinck, Moritz Stephan, Tobias Bocksrocker, Michael Bruns, Christian Kübel, Annie K.Powell, Geoffrey A. Ozin, and Uli Lemmer "Multicolor Silicon Light-Emitting Diodes (SiLEDs)," *Nano Lett* 13(2), 475-480 (2013). DOI: 10.1021/nl3038689.
- [30] Krasilenko, V. G., Nikolskyy, A. I., Lazarev, A. A., "Multichannel serial-parallel analog-to-digital converters based on current mirrors for multi-sensor systems", *Proc. SPIE* Vol. 8550, *Optical Systems Design 2012*, 855022 (January 3, 2013); doi:10.1117/12.2001703.
- [31] Mori, M., Yatagai, T., "Optical learning neural networks with two dimensional structures," *Proc. SPIE* 3402, 226-232 (1997).
- [32]Krasilenko, V.G., Bogukhvalskiy, A.K., Magas A.T., "Designing and simulation optoelectronic neural networks with help of equivalent models and multivalued logics," *Proc. SPIE* 2824, 135-146 (1996).

- [33] Krasilenko, V. G., Nikolsky, A. I., Lazarev, A. A. [Design and Simulation of Time-Pulse Coded Optoelectronic Neural Elements and Devices, Optoelectronic Devices and Properties], InTech (2011). ISBN: 978-953-307-204-3, DOI: 10.5772/16175.
- [34] Krasilenko, V. G., Nikolsky, A. I., Lazarev, A. A., [Design and Modeling of Optoelectronic Photocurrent Reconfigurable (OPR) Multifunctional Logic Devices (MFLD) as the Universal Circuitry Basis for Advanced Parallel High- Performance Processing, Optoelectronics - Advanced Materials and Devices], InTech (2013). ISBN: 978-953-51-0922-8, DOI: 10.5772/54540.
- [35] Krasilenko, V.G., Bardachenko, V.F.,Nikolsky, A.I., Lazarev, A.A. "Programmed optoelectronic time-pulse coded relational processor as base element for sorting neural networks", Proceedings of SPIE Vol. 6576 (SPIE, Bellingham, WA 2007), 657610.
- [36] Huang Kung-S., Yenkin, B., Sawchuk, A., "Image algebra representation of parallel optical binary arithmetic," Applied Optics 28(6), 1263-1278 (1989).
- [37] Wang, Jian, and Yun Long. "M-ary Optical Computing." Cloud Computing-Architecture and Applications. InTech, 2017.
- [38] Guilfoyle, P., McCallum, D., "High-speed low-energy digital optical processors," Opt. Eng. 35(2), 436-442 (1996).
- [39] Pituach, Herzelia. "Enlight256." White paper report, Lenslet Ltd., Israel (2003).
- [40] Krasilenko, V.G., Bardachenko, V.F.,Nikolsky, A.I., Lazarev, A.A., Kolesnytsky, O.K. "Design of optoelectronic scalar-relation vector processors with time-pulse coding," Proc. SPIE 5813, 333-341 (2005).
- [41] Krasilenko, V. G., Nikolsky, A. I., Lazarev, A. A., Lazareva, M.V. "Design and simulation of programmable relational optoelectronic time-pulse coded processors as base elements for sorting neural networks", Proceedings of SPIE Vol. 7723, 77231G (2010).
- [42] Krasilenko, V. G., Nikolsky, A. I., Lazarev, A. A., "Simulation of reconfigurable multifunctional continuous logic devices as advanced components of the next generation high-performance MIMO-systems for the processing and interconnection", Proceedings of SPIE Vol. 9009, 90090R (2014).
- [43] Kolesnitsky, O. K., Krasilenko, V. G., "Analog-to-digital converters with picture organization for digital optoelectronic processors", Autometric, 2, 16-29 (1992).
- [44] Kozhemjako, V. P., Krasilenko, V. G., Kolesnitsky, O. K., "Converters of halftone images in binary slices for digital optoelectronic processors," Proc. SPIE 1806, 654-658 (1993).
- [45] Krasilenko, V. G., Nikolsky, A. I., Krasilenko, O. V., Nikolska, M. A., "Continuously logical complementary: dual equivalently analog-to-digital converters for the optical systems," Proc. SPIE 8001-30, (2011).
- [46] Mostafa Chakir, Hicham Akhamal, and Hassan Qjidaa, "A Design of a New Column-Parallel Analog-to-Digital Converter Flash for Monolithic Active Pixel Sensor," The Scientific World Journal, vol. 2017, Article ID 8418042, 15 pages, 2017. doi:10.1155/2017/8418042.
- [47] Salahuddin, N. S., Wibowo, E. P., Mutiara, A. B., & Painsavoine, M. (2011). Design of Thin-Film-Transistor (TFT) Arrays Using Current Mirror Circuits. In *Livre/Conférence Journal of Engineering, Computing, Sciences & Technology, Asian Transactions* (Vol. 1, pp. 55-59).
- [48] Musa, P., Sudiro, S.A., Wibowo, E.P., Harmanto, S., Painsavoine, M. (2012), "Design and implementation of non-linear image processing functions for CMOS image sensor", Optoelectronic Imaging and Multimedia Technology II, Proc. of SPIE Vol. 8558 <http://spie.org/Publications/Proceedings/Paper/10.1117/12.2000538>.
- [49] Długosz, R. & Iniewski, K., "Flexible Architecture of Ultra-Low-Power Current-Mode Interleaved Successive Approximation Analog-to-Digital Converter for Wireless Sensor Networks" (2007), VLSI Design, vol. 2007, Article ID 45269, 13 pages.
- [50] Indrani Roy, Suman Biswas, B. S. Patro „Low Power High Speed Differential Current Comparator“, International Journal of Innovative Research in Computer and Communication Engineering Vol. 3, Issue 4, April 2015, pp. 3010-3016, DOI: 10.15680/ijirce.2015.0304089.

- [51] Krasilenko, V. G., Nikolsky, A. I., Lazarev, A. A., Krasilenko, O. V., Krasilenko, I. A., "Simulation of continuously logical ADC (CL ADC) of photocurrents as a basic cell of image processor and multichannel optical sensor systems", Proceedings of SPIE Vol. 8774, 877414 (2013).
- [52] Rath, A., Mandal, S. K., Das, S., & Dash, S. P. A High Speed CMOS Current Comparator in 90 nm CMOS Process Technology. International Journal of Computer Applications (0975 – 8887) International Conference on Microelectronics, Circuits and Systems (MICRO-2014).
- [53] Krasilenko V.G., Nikolsky, A. I., Parashuk A.V., "Research of dynamic processes in neural networks with help of system energy equivalence functions," Proc. the 8-th STC Measuring and computer devices in technological processes №8 , pp. 325-330 (2001).
- [54] Perju Veacheslav, David Casasent, "Optical multichannel correlators for high-speed targets detection and localization," Proceedings of SPIE Vol. 8398, 83980C (2012).
- [55] Rudenko OG, Bodiansky EV Artificial neural networks. - Kharkov: OOO SMIT Company, 2005. – 408p.
- [56] Krasilenko V.G., Nikolsky, A. I., Pavlov S. N., "The associative 2D-memories based on matrix-tensor equivalental models," Radioelektronika Informatics Communication, No. 2 (8), 45-54 (2002).
- [57] Krasilenko, V. G., Nikolsky, A. I., Lazarev A.A., Lobodzinska R.F., "Design of neurophysiologically motivated structures of time-pulse coded neurons," Proc. SPIE Vol. 7343, (2009).
- [58] Krasilenko, V. G., Nikolsky, A. I., Lazarev A.A., Magas T.E., "Design and simulation of optoelectronic complementary dual neural elements for realizing a family of normalized vector 'equivalence-nonequivalence' operations," Proceedings of SPIE Vol. 7703, 77030P.
- [59] Krasilenko, V. G., Nikolsky, A. I., Lazarev A.A., Sholohov V. I., "The concept of biologically motivated time-pulse information processing for design and construction of multifunctional devices of neural logic," Proceedings of SPIE Vol. 5421, pp. 183-194 (2004).
- [60] Krasilenko, V. G., Nikolsky, A. I., Lazarev A.A., Magas T.E., "Simulation results of optoelectronic photocurrent reconfigurable (OPR) universal logic devices (ULD) as the universal circuitry basis for advanced parallel high-performance processing," Proceedings of SPIE Vol. 8559, 85590K (2012).
- [61] Krasilenko, V. G., Nikolsky, A. I., Lazarev A.A., Mihalnichenko N.N., "Smart time-pulse coding photo-converters as basic components 2D-array logic devices for advanced neural networks and optical computers," Proceedings of SPIE Vol. 5439, (2004)
- [62] Schlottmann, C. R., Hasler, P. E., "A Highly Dense, Low Power, Programmable Analog Vector-Matrix Multiplier: The FPAA Implementation," in IEEE Journal on Emerging and Selected Topics in Circuits and Systems, vol. 1, no. 3, pp. 403-411, Sept. 2011. doi: 10.1109/JETCAS.2011.2165755
- [63] Krasilenko, V. G., Nikolsky, A. I., Lazarev A.A., "Designing and simulation smart multifunctional continuous logic device as a basic cell of advanced high-performance sensor systems with MIMO-structure," Proceedings of SPIE Vol. 9450, 94500N (2015)
- [64] Krasilenko V.G., Ogorodnik K.V., Nikolsky A.I., Dubchak V. N., "Family of optoelectronic photocurrent reconfigurable universal (or multifunctional) logical elements (OPR ULE) on the basis of continuous logic operations (CLO) and current mirrors (CM)," Proceedings of SPIE Vol. 8001, 80012Q (2011)
- [65] Krasilenko, V. G., Nikolsky, A. I., Lazarev A.A., Pavlov S.N., "Design and applications of a family of optoelectronic photocurrent logical elements on the basis of current mirrors and comparators," Proceedings of SPIE Vol. 5948, 59481G (2005).
- [66] Krasilenko V. G., Lazarev A. A., Nikitovich D. V., "Design and simulation of optoelectronic neuron equivalentors as hardware accelerators of self-learning equivalent convolutional neural structures (SLECNS)," Proceedings of SPIE Vol. 10689, 106890C (2018).
- [67] Rodríguez-Quiñonez, J. C., Sergiyenko, O., Hernandez-Balbuena, D., Rivas-Lopez, M., Flores-Fuentes, W., & Basaca-Preciado, L. C. (2014). Improve 3D laser scanner

- measurements accuracy using a FFBP neural network with Widrow-Hoff weight/bias learning function. *Opto-Electronics Review*, 22(4), 224-235.
- [68] Flores-Fuentes, W., Sergiyenko, O., Gonzalez-Navarro, F. F., Rivas-López, M., Rodríguez-Quinonez, J. C., Hernández-Balbuena, D., ... & Lindner, L. (2016). Multivariate outlier mining and regression feedback for 3D measurement improvement in opto-mechanical system. *Optical and Quantum Electronics*, 48(8), 403.
- [69] Flores-Fuentes, W., Rodríguez-Quinonez, J. C., Hernández-Balbuena, D., Rivas-Lopez, M., Sergiyenko, O., Gonzalez-Navarro, F. F., & Rivera-Castillo, J. (2014, June). Machine vision supported by artificial intelligence. In *Industrial Electronics (ISIE), 2014 IEEE 23rd International Symposium on* (pp. 1949-1954). IEEE.