

Всеукраїнський науково-технічний журнал

All-Ukrainian Scientific & Technical Journal

ISSN 2520-6168 (Print)

DOI:10.37128/2520-6168-2024-2



№2 (125)



2024

**Machinery  
Energetics  
Transport  
of Agribusiness**

**ТЕХНІКА  
ЕНЕРГЕТИКА  
ТРАНСПОРТ АПК**



*Науковий журнал*

**ТЕХНІКА,  
ЕНЕРГЕТИКА,  
ТРАНСПОРТ АПК**

*№ 2 (125) / 2024*

**м. Вінниця - 2024**

*Scientific Journal*

**Engineering,  
Energy, Transport  
AIC**

*Vol 125, № 2 / 2024*

**Vinnytsia – 2024**

**ТЕХНІКА,  
ЕНЕРГЕТИКА,  
ТРАНСПОРТ АПК**

Журнал науково-виробничого та навчального спрямування  
Видавець: Вінницький національний аграрний університет

Заснований у 1997 році під назвою «Вісник Вінницького державного сільськогосподарського інституту».

Правонаступник видання: Збірник наукових праць Вінницького національного аграрного університету. Серія: Технічні науки.

Свідоцтво про державну реєстрацію засобів масової інформації  
КВ № 16644–5116 ПР від 30.04.2010 р.

Науковий журнал. *Техніка, енергетика, транспорт АПК*. 2024. № 2 (125). С. 1–142.

Друкується за рішенням Вченої ради Вінницького національного аграрного університету (протокол № 2 від 30.08.2024 р.)

Свідоцтво про державну реєстрацію засобів масової інформації №21906-11806 Р від 12.03.2016р.

Журнал «Техніка, енергетика, транспорт АПК» включено до переліку наукових фахових видань України з технічних наук (Категорія «Б», Наказ Міністерства освіти і науки України від 02.07.2020 року №886);

Згідно рішення Національної ради України з питань телебачення та радіомовлення від 25.04.2024 р. №1337 науковому журналу «Техніка, енергетика, транспорт АПК» присвоєно ідентифікатор медіа R30-05173.

- присвоєно ідентифікатор цифрового об'єкта (*Digital Object Identifier – DOI*);

- індексується в *CrossRef, Google Scholar*;

- індексується в міжнародній наукометричній базі *Index Copernicus Value* з 2018 року.

Головний редактор

**Олексій ТОКАРЧУК** – к.т.н., доцент,  
Вінницький національний аграрний університет

Заступник головного редактора

**Наталія ВЕСЕЛОВСЬКА** – д.т.н., професор,  
Вінницький національний аграрний університет

Відповідальний секретар

**Юрій ПОЛЄВОДА** – к.т.н., доцент, Вінницький  
національний аграрний університет

Члени редакційної колегії

**Анатолій СПІРІН** – к.т.н., доцент,  
Вінницький національний аграрний університет

**Олег ЦУРКАН** – д.т.н., професор,  
Вінницький національний аграрний університет

**Валерій ГРАНЯК** – к.т.н., доцент,  
Вінницький національний аграрний університет

**Олена СОЛОНА** – к.т.н., доцент,  
Вінницький національний аграрний університет

**Віталій ЯРОПУД** – к.т.н., доцент,  
Вінницький національний аграрний університет

**Ігор ТВЕРДОХЛІБ** – к.т.н., доцент,  
Вінницький національний аграрний університет

**Володимир БУЛГАКОВ** – д.т.н., професор,  
академік НААН України, Національний  
університет біоресурсів і природокористування  
України

**Ростислав ІСКОВИЧ-ЛОТОЦЬКИЙ** – д.т.н.,  
професор, Вінницький національний технічний  
університет

**Ігор КУПЧУК** – к.т.н., доцент,  
Вінницький національний аграрний університет

**Ярослав ІВАНЧУК** – к.т.н., доцент,  
Вінницький національний технічний університет

Зарубіжні члени редакційної колегії

**Йордан Максимов** – д.т.н., професор, Технічний  
університет Габрово (Болгарія)

**Аудріус Жунда** – к.т.н., доцент, Університет Вітовта  
Великого (Литва)

відповідальний секретар редакції – Полєвода Ю.А. к.т.н., доцент,

літературний редактор української та іноземних мов – Погранична Н.М.,

Адреса редакції: 21008, Вінниця, вул. Сонячна 3, Вінницький національний аграрний університет, тел. (0432) 46–00–03

Сайт журналу: <http://tetapk.vsau.org/>

Електронна адреса: [pophv@ukr.net](mailto:pophv@ukr.net)

Journal of scientific, industrial and educational direction

**ENGINEERING,  
ENERGY,  
TRANSPORT AIC**

Publisher: Vinnytsia National Agrarian University

It was founded in 1997 under the name "Bulletin of the Vinnytsia State Agricultural Institute".

Successor publication: Collection of Scientific Works of the Vinnytsia National Agrarian University. Series: Technical sciences.

Certificate of state registration of mass media

KV No. 16644–5116 PR dated 04/30/2010

Scientific Journal. (2024). *Technology, Energy, Transport AIC*, Vol. 125, № 2, P. 1–142.

Printed by decision of the Academic Council of the Vinnytsia National Agrarian University (protocol №. 2 dated August 30, 2024)

Certificate of state registration of mass media №. 21906-11806 R dated March 12, 2016.

The journal "Technology, Energy, Transport of the Agricultural Industry" is included in the list of technical scientific publications of Ukraine (Category "B", Order of the Ministry of Education and Science of Ukraine dated July 2, 2020 №. 886);

According to the decision of the National Council of Ukraine on Television and Radio Broadcasting dated April 25, 2024 №. 1337, the scientific journal "Technology, Energy, Transport of the Agricultural Industry" was assigned the media identifier R30-05173.

- assigned a digital object identifier (Digital Object Identifier - DOI);
- indexed in CrossRef, Google Scholar;
- indexed in the international scientometric database Index Copernicus Value since 2018.

Chief editor

**Olexii TOKARCHUK** – Candidate of Technical Sciences, Associate Professor, Vinnytsia National Agrarian University (Ukraine)

Deputy editor-in-chief

**Natalia VESELOVSKA** – Doctor of Technical Sciences, Full Professor, VNAU (Ukraine)

Responsible secretary

**Yuriy POLIEVODA** – Candidate of Technical Sciences, Associate Professor, VNAU (Ukraine)

Members of the editorial board

**Anatoly SPIRIN** – Candidate of Technical Sciences, Associate Professor, Vinnytsia National Agrarian University (Ukraine)

**Oleg TSURKAN** – Doctor of Technical Sciences, Full Professor, Vinnytsia National Agrarian University (Ukraine)

**Valerii HRANIAK** – Candidate of Technical Sciences, Associate Professor, Vinnytsia National Agrarian University (Ukraine)

**Olena SOLONA** – Candidate of Technical Sciences, Associate Professor, Vinnytsia National Agrarian University (Ukraine)

**Vitalii YAROPUD** – Candidate of Technical Sciences, Associate Professor, Vinnytsia National Agrarian University (Ukraine)

**Igor TVERDOKHLIB** – Candidate of Technical Sciences, Associate Professor, Vinnytsia National Agrarian University (Ukraine)

**Volodymyr BULGAKOV** – Doctor of Technical Sciences, Full Professor, Acad. NAAS, National University of Life and Environmental Sciences of Ukraine (Ukraine)

**Rostislav ISKOVICH-LOTOTSKY** – Doctor of Technical Sciences, Full Professor, Vinnytsia National Technical University (Ukraine)

**Igor KUPCHUK** – Candidate of Technical Sciences, Associate Professor, Vinnytsia National Agrarian University (Ukraine)

**Yaroslav IVANCHUK** – Doctor of Technical Sciences, Associate Professor, Vinnytsia National Technical University (Ukraine)

Foreign members of the editorial board

**Jordan Todorov MAXIMOV** – Doctor of Technical Sciences, Full Professor, Technical University of Gabrovo (Bulgaria)

**Audrius ŽUNDA** – Ph.D., Associate Professor, Vytautas Magnus University (Kaunas, Lithuania)

editor-in-chief – **Yurii POLIEVODA**, Candidate of Technical Sciences, Associate Professor, literary editor of Ukrainian and foreign languages – **Natalia POGRANICHNA**

Address of the editorial office: 21008, Vinnytsia, str. Sonyakna 3, Vinnytsia National Agrarian University, tel. (0432)46-00-03

The magazine's website: <http://tetapk.vsau.org/>

E-mail address: [pophv@ukr.net](mailto:pophv@ukr.net)

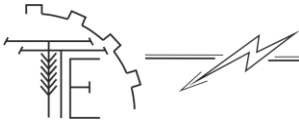

## ЗМІСТ

<b>I. ПРИКЛАДНА МЕХАНІКА. МАТЕРІАЛОЗНАВСТВО. ГАЛУЗЕВЕ МАШИНОБУДУВАННЯ</b>	
<i>АЛІЄВ Ельчин Бахтияр огли, БЕЗВЕРХНІЙ Петро Євгенович, ДУДІН Володимир Юрійович, АЛІЄВА Ольга Юрійівна</i>	
<b>РЕЗУЛЬТАТИ ЕКСПЕРИМЕНТАЛЬНИХ ДОСЛІДЖЕНЬ УДОСКОНАЛЕНОЮ СИСТЕМОЮ ПОДАЧІ НАСІННЯ ПНЕВМАТИЧНОЇ СІВАЛКИ ТОЧНОГО ВИСІВУ.....</b>	<b>7</b>
<i>БАБІН Ігор Анатолійович</i>	
<b>ЕКСПЕРИМЕНТАЛЬНІ ДОСЛІДЖЕННЯ СТЕНДУ АВТОМАТИЗОВАНОЇ СИСТЕМИ ПРОМИВАННЯ ДОЇЛЬНОЇ УСТАНОВКИ З ПОВІТРЯНИМИ ІНЖЕКТОРАМИ ТА ФОТОДАТЧИКОМ ДЛЯ ВИЗНАЧЕННЯ РІВНЯ ЗАБРУДНЕННЯ.....</b>	<b>16</b>
<i>ГРИЦУН Анатолій Васильович, ЗОЗУЛЯК Ігор Анатолійович, БОРИС Микола Михайлович, МАРТИНЮК Андрій Віталійович</i>	
<b>ТЕОРЕТИЧНІ ДОСЛІДЖЕННЯ ПРОЦЕСУ МАШИННОГО ДОЇННЯ КОРІВ АПАРАТОМ З ДОЇЛЬНОЮ ГУМОЮ ПЕРЕМІННОГО ПЕРЕРІЗУ.....</b>	<b>28</b>
<i>КОЗАЧЕНКО Олексій Васильович, АЛІЄВ Ельчин Бахтияр огли, ПІХ Євгеній Олексійович</i>	
<b>ЧИСЕЛЬНЕ МОДЕЛЮВАННЯ ПРОЦЕСУ ПОПЕРЕДНЬОЇ СЕПАРАЦІЇ НАСІННЄВОЇ СУМІШІ НА ГВИНТОВОМУ ЖИВИЛЬНИКУ ВІБРОФРИКЦІЙНОГО СЕПАРАТОРА.....</b>	<b>36</b>
<i>КУДРЯВЦЕВ Ігор Миколайович</i>	
<b>ЧИСЕЛЬНЕ МОДЕЛЮВАННЯ ПРОЦЕСУ СЕПАРАЦІЇ ВІДХОДІВ НАСІННЄВОЇ СУМІШІ СОНЯШНИКУ В ПНЕВМОСЕПАРУЮЧОМУ КАНАЛІ АЕРОДИНАМІЧНОГО СЕПАРАТОРА...</b>	<b>47</b>
<i>ПАЛАДІЙЧУК Юрій Богданович, ГОРОВИЙ Артур Володимирович</i>	
<b>ДОСЛІДЖЕННЯ ФОРМ І ПРИЗНАЧЕННЯ МАКРОРЕЛЬЄФІВ НА РОБОЧИХ ПОВЕРХНЯХ ЦИЛІНДРИЧНИХ ДЕТАЛЕЙ.....</b>	<b>56</b>
<i>ТРОХАНЯК Олександра Миколаївна, ЯРОПУД Віталій Миколайович</i>	
<b>ДОСЛІДЖЕННЯ ГНУЧКОГО ГВИНТОВОГО КОНВЕЄРА ДЛЯ УТИЛІЗАЦІЇ ПОШКОДЖЕНОГО ВІЙСЬКОВИМИ ДІЯМИ ШАРУ ЗЕМЕЛЬ СІЛЬСЬКОГОСПОДАРСЬКОГО ПРИЗНАЧЕННЯ.....</b>	<b>66</b>
<i>ШТУЦЬ Андрій Анатолійович</i>	
<b>ВДОСКОНАЛЕННЯ МЕТОДИКИ ПОБУДУВИ КРИВИХ ГРАНИЧНИХ ДЕФОРМАЦІЇ ДЛЯ ПРОЦЕСІВ ШТАМПУВАННЯ ОБКОЧУВАННЯМ.....</b>	<b>75</b>
<i>ЯРОПУД Віталій Миколайович</i>	
<b>ЕКСПЕРИМЕНТАЛЬНІ ДОСЛІДЖЕННЯ ПРОЦЕСУ НАГРІВУ ПОТОКУ ПОВІТРЯ У ВЕРТИКАЛЬНОМУ ГРУНТОВОМУ ТЕПЛООБМІННИКУ.....</b>	<b>83</b>
<b>II. АГРОІНЖЕНЕРІЯ</b>	
<i>КРАВЕЦЬ Світлана Миколаївна, ТОКАРЧУК Олексій Анатолійович</i>	
<b>ІНТЕГРАЦІЯ ШТУЧНОГО ІНТЕЛЕКТУ В НАВЧАЛЬНИЙ ПРОЦЕС СТУДЕНТІВ СПЕЦІАЛЬНОСТІ АГРОІНЖЕНЕРІЯ.....</b>	<b>91</b>
<i>РЯБОШАПКА Вадим Борисович, МЕЛЬНИК Віталій Олегович</i>	
<b>ПРИЧИНИ ЗНОШУВАННЯ ПЛУНЖЕРНИХ ПАР ТА ПІДВИЩЕННЯ ЇХ ДОВГОВІЧНОСТІ ЗА РАХУНОК ВИКОРИСТАННЯ БІОПАЛИВА.....</b>	<b>99</b>
<i>ТВЕРДОХЛІБ Ігор Вікторович, ПОЛЄВОДА Юрій Алікович, СЛОБОДЯНЮК Віктор Володимирович, ПАВЛЕНКО Владислав Костянтинівич</i>	
<b>КОНСТРУКЦІЙНО-ТЕХНОЛОГІЧНІ ПАРАМЕТРИ ТА РЕЖИМИ РОБОТИ ПРОЦЕСУ ПОДРІБНЕННЯ ЗЕЛЕНОЇ МАСИ ЕНЕРГО- ТА РЕСУРСООЩАДНОГО ВИРОБНИЦТВА ПРОДУКЦІЇ ТВАРИННИЦТВА.....</b>	<b>105</b>
<i>ХОЛОДЮК Олександр Володимирович, КАВУНОВ Владислав Віталійович, ХРИЩЕНЮК Владислав Валерійович</i>	
<b>РОЗРОБКА СИСТЕМИ ДИСТАНЦІЙНОГО ВИЯВЛЕННЯ ВИБУХОНЕБЕЗПЕЧНИХ ПРИСТРОЇВ ТА ЗАБРУДНЕНЬ НА СІЛЬСЬКОГОСПОДАРСЬКИХ УГІДДЯХ.....</b>	<b>111</b>
<b>III. ЕЛЕКТРОЕНЕРГЕТИКА, ЕЛЕКТРОТЕХНІКА ТА ЕЛЕКТРОМЕХАНІКА</b>	
<i>ГРАНЯК Валерій Федорович, КУПЧУК Ігор Миколайович, ЗЛОТНІЦЬКИЙ В'ячеслав Миколайович, САФТЮК Ярослав Владиславович</i>	
<b>ОСОБЛИВОСТІ ВПЛИВУ ТЕХНІЧНИХ ПАРАМЕТРІВ АСИНХРОННОГО ДВИГУНА НА ФОРМУВАННЯ ТРИФАЗНОЇ СИСТЕМИ СТРУМУ СТАТОРА.....</b>	<b>124</b>
<i>ЧУМАК Вадим Володимирович, ДУХНО Роман Павлович, СТУЛІШЕНКО Андрій Сергійович, СВЯТНЕНКО Вадим Анатолійович</i>	
<b>ВИСОКОЧАСТОТНІ ПРОЦЕСИ В ОБМОТКАХ ЕЛЕКТРИЧНИХ МАШИН ЗАГАЛЬНОГО ПРИЗНАЧЕННЯ ПРИ НАЯВНОСТІ ДЕФЕКТІВ КОРПУСНОЇ ІЗОЛЯЦІЇ..</b>	<b>130</b>

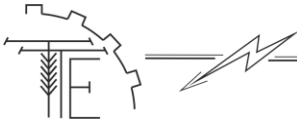

## CONTENTS

## I. APPLIED MECHANICS. MATERIALS SCIENCE. INDUSTRY MACHINERY BUILDING

<i>Elchyn ALIIEV, Petro BEZVERKHNIY, Volodymyr DUDIN, Olha ALIIEVA</i> <b>RESULTS OF EXPERIMENTAL STUDIES ON THE IMPROVED SEED DELIVERY SYSTEM OF A PNEUMATIC PRECISION SEEDER.....</b>	<b>7</b>
<i>Ihor BABYN</i> <b>EXPERIMENTAL STUDIES OF THE STAND OF THE AUTOMATED MILKING UNIT WASHING SYSTEM WITH AIR INJECTORS AND A PHOTO SENSOR FOR DETERMINING THE CONTAMINATION LEVEL.....</b>	<b>16</b>
<i>Anatolii HRYTSUN, Igor ZOZULYAK, Mykola BORYS, Andrii MARTYNYUK</i> <b>THEORETICAL STUDIES OF THE PROCESS OF MACHINE MILKING OF COWS WITH AN APPARATUS WITH MILKING RUBBER VARIABLE THICKNESS.....</b>	<b>28</b>
<i>Oleksii KOZACHENKO, Elchyn ALIIEV, Yevhenii PIKH</i> <b>NUMERICAL SIMULATION OF THE PROCESS OF PRELIMINARY SEPARATION OF THE SEED MIXTURE ON THE SCREW FEEDER OF THE VIBRO-FRICTION SEPARATOR.....</b>	<b>36</b>
<i>Ihor KUDRIAVTSEV</i> <b>NUMERICAL SIMULATION OF THE WASTE SEPARATION PROCESS OF SUNFLOWER SEED MIXTURE IN THE PNEUMATIC SEPARATING CHANNEL OF THE AERODYNAMIC SEPARATOR.....</b>	<b>47</b>
<i>Yuriy PALADIYCHUK, Artur HOROVYI</i> <b>STUDY OF THE FORMS AND PURPOSE OF MACRO-RELIEF ON THE WORKING SURFACES OF CYLINDRICAL PARTS.....</b>	<b>56</b>
<i>Oleksandra TROKHANIAK, Vitalii YAROPUD</i> <b>RESEARCH OF A FLEXIBLE SCREW CONVEYOR FOR DISPOSAL OF AGRICULTURAL LAND DAMAGED BY MILITARY ACTIONS.....</b>	<b>66</b>
<i>Andrii SHTUTS</i> <b>IMPROVEMENT OF THE METHOD OF CONSTRUCTING LIMIT DEFORMATION CURVES FOR ROLL STAMPING PROCESSES.....</b>	<b>75</b>
<i>Vitalii YAROPUD</i> <b>EXPERIMENTAL STUDIES OF THE AIR FLOW HEATING PROCESS IN A VERTICAL SOIL HEAT EXCHANGER.....</b>	<b>83</b>

## II. AGROENGINEERING

<i>Svitlana KRAVETS, Oleksii TOKARCHUK</i> <b>INTEGRATION OF ARTIFICIAL INTELLIGENCE IN THE EDUCATIONAL PROCESS OF AGRO ENGINEERING STUDENTS.....</b>	<b>91</b>
<i>Vadym RYABOSHAPKA, Vitalii MELNYK</i> <b>REASONS FOR WEAR OF PLUNGER PAIRS AND INCREASING THEIR DURABILITY DUE TO THE USE OF BIOFUEL.....</b>	<b>99</b>
<i>Igor TVERDOKHLIB, Yurii POLIEVODA, Viktor SLOBODYANYUK, Vladyslav PAVLENKO</i> <b>CONSTRUCTION AND TECHNOLOGICAL PARAMETERS OF THE PROCESS OF REDUCING GREEN MASS OF ENERGY- AND RESOURCE-SAVING PRODUCTION OF LIVESTOCK PRODUCTS.....</b>	<b>105</b>
<i>Oleksandr KHOLODIUK, Vladyslav KAVUNOV, Vladyslav KHRYSHCHENIUK</i> <b>DEVELOPMENT OF A SYSTEM FOR REMOTE DETECTION OF EXPLOSIVE DEVICES AND POLLUTION ON AGRICULTURAL LANDS.....</b>	<b>111</b>

## III. ELECTRICAL ENERGY, ELECTRICAL ENGINEERING AND ELECTROMECHANICS

<i>Valerii HRANIAK, Ihor KUPCHUK, Viacheslav ZLOTNITSKYI, Yaroslav SAFTYUK</i> <b>FEATURES OF THE INFLUENCE OF THE TECHNICAL PARAMETERS OF ASYNCHRONOUS MOTOR ON THE FORMATION OF IT'S THREE-PHASE STATOR CURRENT SYSTEM.....</b>	<b>124</b>
<i>Vadym CHUMAK, Roman DUKHNO, Andriy STULISHENKO, Vadym SVYATNENKO</i> <b>HIGH-FREQUENCY PROCESSES IN THE WINDINGS OF GENERAL-PURPOSE ELECTRICAL MACHINES IN THE PRESENCE OF DEFECTS IN THE GROUND-WALL INSULATION.....</b>	<b>130</b>

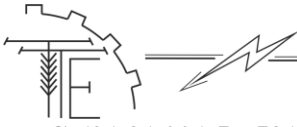
UDC 621.91.001.57:531.81.003.12  
DOI: 10.37128/2520-6168-2024-2-6**STUDY OF THE FORMS AND PURPOSE OF MACRO-RELIEF ON THE WORKING SURFACES  
OF CYLINDRICAL PARTS**

**Yuriy PALADIYCHUK**, Candidate of Technical Sciences, Associate Professor  
**Artur HOROVYI**, Postgraduate  
Vinnytsia National Agrarian University

**ПАЛАДІЙЧУК Юрій Богданович**, к.т.н., доцент  
**ГОРОВИЙ Артур Володимирович**, аспірант  
Вінницький національний аграрний університет

*Modern trends in engineering and agricultural industry emphasize the importance of using methods and tools to improve the reliability of individual parts and products as a whole, as well as to reduce the cost of products. The reliability of machine parts is determined by a number of parameters, such as strength, wear resistance, vibration and thermal resistance. In order to achieve these criteria for the reliability of machine parts, it is necessary to take into account various manufacturing methods and improve material processing technologies. An important aspect is also the use of composite and innovative materials that can significantly improve the characteristics of products. In addition, the introduction of automation and digital technologies allows to optimize production processes and reduce the probability of defects.*

*The study of the forms and purpose of macroreliefs on the working surfaces of cylindrical parts is an actual problem in the field of metalworking and mechanical engineering.*

*The subject of analysis was the properties and effectiveness of macroreliefs in the metalworking process, in particular their influence on the quality and functionality of products. The work includes an overview of various types of macroreliefs, their purpose and application in production conditions, taking into account the specific requirements of the technological process.*

*The methods of forming macroreliefs, including processing technologies and their influence on the technical characteristics and quality of the final product, are highlighted. The results of the study showed that the use of macroreliefs can improve the technological capabilities of processing parts, ensure an increase in their strength and stability, as well as improve the appearance and aesthetics of the product.*

*The obtained results are of practical importance for engineers and designers engaged in the development and production of cylindrical parts in various industries, such as automotive, mechanical engineering, aerospace and other industries where it is important to achieve optimal quality and production efficiency.*

**Key words:** *research, macroreliefs, working surfaces, cylindrical parts, forms, purposes.*

**Fig. 14. Ref. 8.**

---

**1. Problem formulation**

---

One of the methods of improving the physical and mechanical properties of cylindrical parts is the formation of macroreliefs with an integrated tool during deforming drawing.

Macroreliefs are profiles of the work surface that create channels for parts caused by physical and technological processes. In materials science, macroreliefs can be visible on the raw surfaces of materials or created specifically for certain functions. These channels can vary in shape, size, and depth, and they affect the distribution and movement of lubricant, coolant, or gas across the surface, which is important for various applications. Macroreliefs help reduce friction and wear, providing longer life for materials in mechanical systems.

Macrorelief profiles are channels on the surfaces of parts (Fig. 1.1.), which can be of different depths and shapes, used to control the physical processes of machine nodes. Macrorelief profiles include hand tool enhancements, firearms and explosives enhancements, jointing and rolling for a variety of needs and materials, efficient milling cutters for woodworking and other materials, and embossed shafts for better blade retention and aesthetic appeal. the appearance of parts and products.





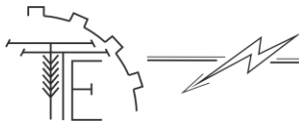

It is promising to use macroreliefs in nodes and mechanisms to control fluid flows, reduce friction and wear, supply lubricating and cooling fluid, create residual reservoirs for lubricants or dirt, improve the frictional properties of parts, use to control longitudinal movement in connection with rotating and in general, increasing the reliability, functionality and service life of parts.

In Autodesk Fusion 360, for example, several different types of reliefs were designed on the machining surface for forced chip separation (Fig. 1.)

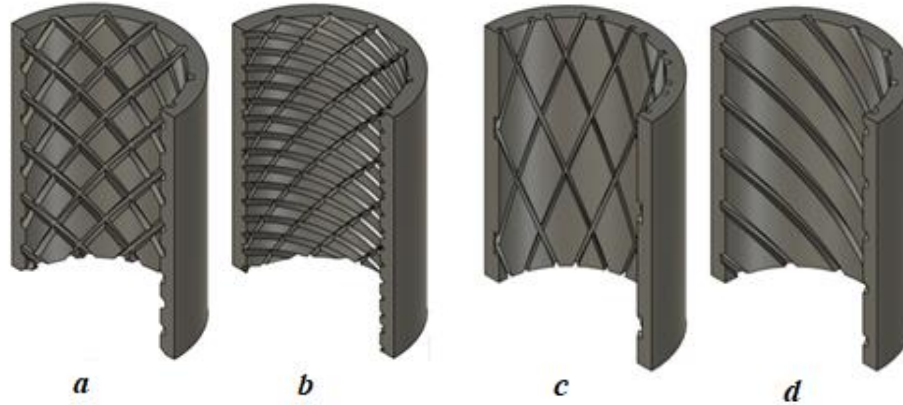

**Fig. 1. Types of macrorelief profile:**

a) relief formed due to two self-rotating relief-forming sections with the same angle of deforming elements on them, left and right rotation; b) relief, where on one relief-forming section the angle of the deforming element has been changed to a greater side relative to the first section, where the angle of the deforming element has remained unchanged; c) when the angle of the deforming elements is reduced, the groove formation step increases; d) with unilateral rotation of one relief-forming section.

The use of macroreliefs of various profiles and groove shapes in hydro, pneumatic and other nodes where the bypass of technical fluids plays a significant role, makes it possible to improve the uniformity of pressure distribution and reduce friction, can provide control of speed and direction of movement, and in nodes such as shock absorbers serve to improve absorption of shocks and stability of the car during movement.

## 2. Analysis of recent research and publications

In modern mechanical engineering, high demands are placed on processed materials, in particular, on the quality of structural carbon steels. The specifics of these requirements cover aspects such as the range of blanks, which include pipe rolls, as well as mechanical properties such as tensile strength ( $\delta_B$ ), which is in the range of 260 to 610 MPa, and the hardness according to the HV method, which is from 650 to 2000 MPa.

One of the examples of the use of macroreliefs is the manufacture of carvings.

In this case, macroreliefs are used to create ridges and grooves of different profiles (Fig. 2.), which form threads necessary for connecting various elements of machines, equipment, mechanisms and creating gears.

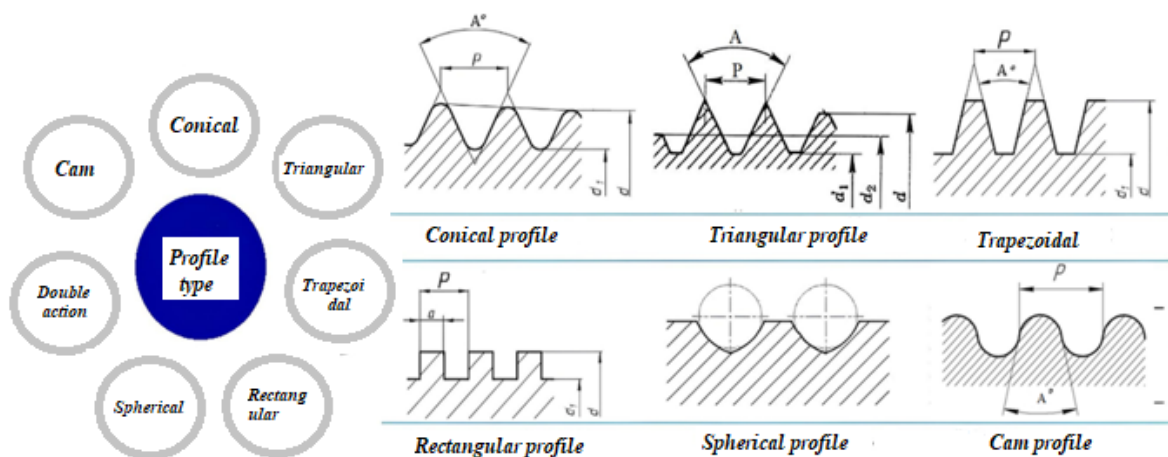

**Fig. 2. Kinds of macrorelief groove profile**



**Fig. 3. Ball-screw transmission**

An illustrative example of the formation of such macroreliefs is a ball-screw transmission (Fig. 3.) where the motion transmission method uses a screw shaft with grooves of a spherical profile, in which balls are placed. As the shaft rotates, the balls circulate in the grooves, which causes the nut with the same relief to move along the shaft.

Such a system provides high efficiency and accuracy of movement, and also saves electricity, as it requires less torque for operation. It is worth noting that the formation of such reliefs is possible in many ways, but the most effective can be considered the rolling method, which has forming rollers as working elements (Fig. 4) and uses the method of surface plastic deformation.

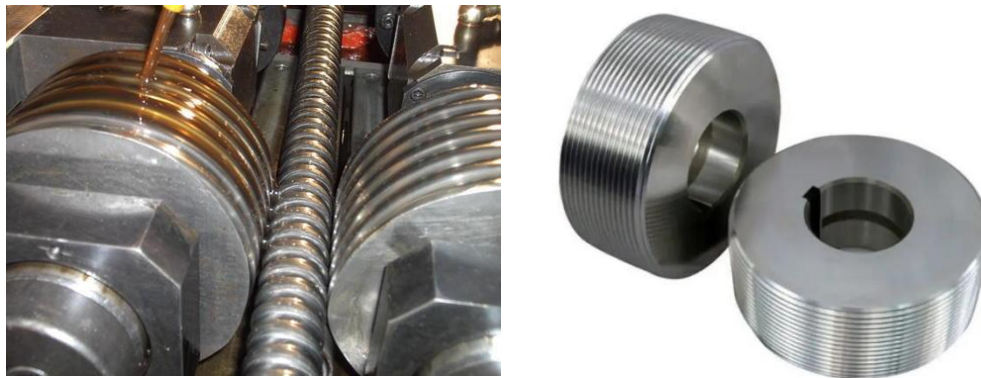

**Fig. 4. Rolling method and forming rollers**

The method of surface plastic deformation includes mechanical impact on the surface layer of the material in order to change its crystal lattice and structure. During this process, deformation forces force the atoms of the material to move, which can lead to a change in their position in the crystal lattice.

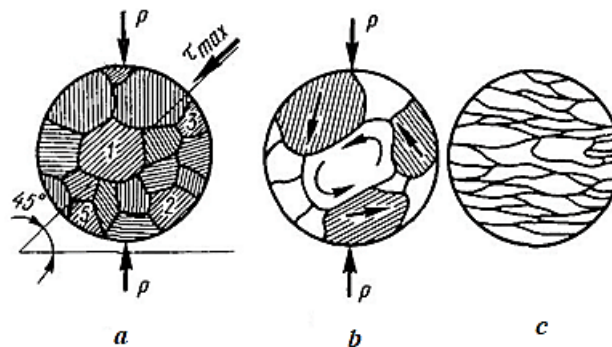
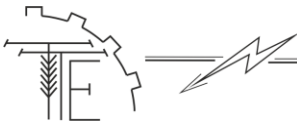

**Fig. 5. The process of surface plastic deformation**

The sliding of atomic layers takes place, first of all, along those planes, the direction of which forms an angle of  $45^\circ$  (Fig. 5, a) relative to the direction of action of the compressive force  $R$ . As a result of plastic deformation (Fig. 5, b), the crystals are stretched in the direction of the greatest flow of metal and acquire elongated shape (Fig. 5, c).

A similar method can be used to create macroreliefs on various hand tools, devices, buttons and other objects. For example, they can be used on medical instruments to facilitate their maintenance, identification and cleaning.

The following are important functions of macroreliefs:



1) Improved grip: the macro-relief structure of such tools provides a better grip, which makes it easier to hold onto the handle when using various tools or tools, such as medical tools, wrenches, screwdrivers, dumbbells, vultures, weapons, etc.;

2) Improved control: Macro relief helps provide better control over tools or implements, reducing the risk of losing control or slipping while working. This contributes to the improvement of safety and efficiency of tasks;

3) Reducing the load on the hands: macroreliefs allow you to distribute the weight over a larger surface area of the hand, which reduces stress and the risk of injury to the hands during work. This helps to maintain comfort during long-term use of work tools or tools.

Many technological processes can be used to form such macroreliefs (Fig. 6), but it is worth paying attention to those methods that make it possible to form them on cylindrical surfaces:

- 1) Laser engraving;
- 2) Milling or lathe engraving;
- 3) Knurl.



*Fig. 6. Macroreliefs on hand tools*

Although macroreliefs can be formed through laser engraving, there are a number of disadvantages that make this method ineffective and unattractive for constant use, namely:

- limited Engraving Depth: Laser engraving can be limited in processing depth, meaning the macro reliefs may not be deep enough to effectively improve grip and perform the desired functions;
- high costs: Laser equipment and its operation can be extremely expensive, especially for small production or individual projects;
- potential for thermal warping: The laser engraving process can heat up the metal surface, which can cause thermal warping, especially in thin or small parts;
- material limitations: Some materials may be less suitable for laser engraving due to their composition or structure. For example, some metals can be difficult to process due to high thermal conductivity or reaction to laser exposure.

Macroreliefs can be created by engraving on milling and turning machines using various cutters and cutters. However, for the effective formation of such reliefs, it is recommended to use CNC machines with at least four axial directions. This is explained by the fact that the specifics of the work of traditional lathes and milling machines do not always allow to effectively form such reliefs.

The most effective method of creating relief for improving the grip on various tools and instruments is the rolling method. In this method, a special tool is fixed, usually on the lathe, in the cutter holder or tailstock. It is a highly efficient multi-roll device that allows you to create a macrorelief in the form of a grid in a single pass, without the need to spend time repositioning or readjusting the tool, as is necessary with the single-roll method.

This method is also effective for the manufacture of slotted joints with a triangular profile (Fig. 8 c), we can separately emphasize the tool shown in Figure 7, which is an effective solution for the formation of short longitudinal reliefs (slots), such a tool ensures high accuracy of their formation and reducing the load on the machine components (reducing the compression of the part).

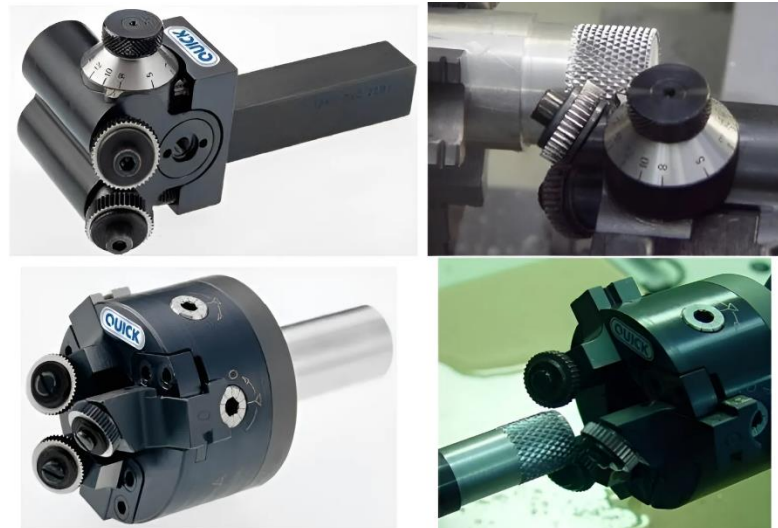

**Fig. 7. Rolling tool**

The tool is based on the method of surface-plastic deformation, which makes it possible to form macroreliefs in the form of a grid, thread, notch and other reliefs.

The method is based on the plastic properties of the metal, which allows obtaining residual deformation without violating the integrity of the material, forming takes place without removing chips. The tool (roller or rollers) is pressed into the material, which leads to surface deformation and forms the corresponding profile. This approach makes it possible to simplify the processing process and reduce waste.

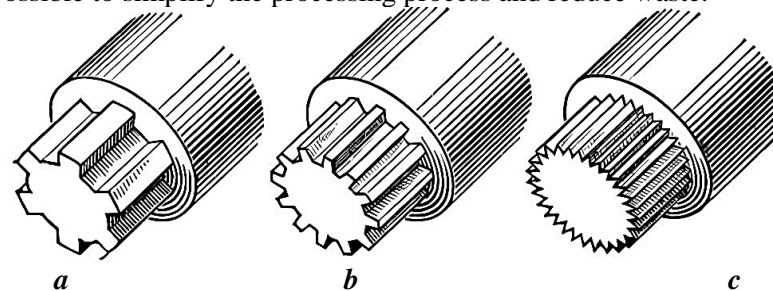

**Fig. 8. Profile types of slotted joints: a) – rectangular profile; b) – involute profile; c) – triangular profile**

Macroreliefs in the form of longitudinal straight channels on the surface make it possible to form slots, which is an effective and reliable way of connecting various types of moving (sliding) and static shafts, such as half-axles, cardan shafts, couplings, etc.

Such connections have a higher load capacity compared to the alternative key method, which creates a lower stress concentration in the shafts, which ensures their higher durability, contributes to better centering of parts on the shafts, and is more convenient for mass and serial production.

They are also distinguished by the types of reliefs (Fig. 8).

Slotted joints can have different types of profiles, such as rectangular (Fig. 8, a), involute (Fig. 8, b) and triangular (Fig. 8, c). The choice of a specific profile depends on specific requirements for strength, load and other factors that affect the functionality of the slotted connection.

Rollers, or rollers, are specialized equipment designed for grinding, crushing, pressing loose materials and grain crops. They are used both in food and in other industries where they are of great importance.

As an example, the flour mill rollers shown in Figure 9 a are used for grinding cereals and are a key component of mills in flour mills, which can be manufactured by rolling.

The grain grinding process is carried out by rolling the grain between a pair of rolls with macroreliefs on them, which rotate in opposite directions, and due to the pressure, the grain is split, then in turn it is divided into fractions for further processing, from which bran and flour are formed.

In Figure 9. b depicts rollers, or as they are also called rollers, intended for use in granulators that directly press raw materials into the matrix, which contributes to the formation of finished granules. For better performance and productivity, macrorelief is formed on them in the form of longitudinal grooves and, unlike

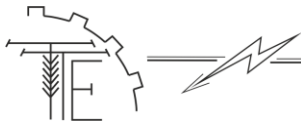

flour mill rollers, they have a larger step around the circumference and depth of the groove, which complicates their manufacture by rolling.

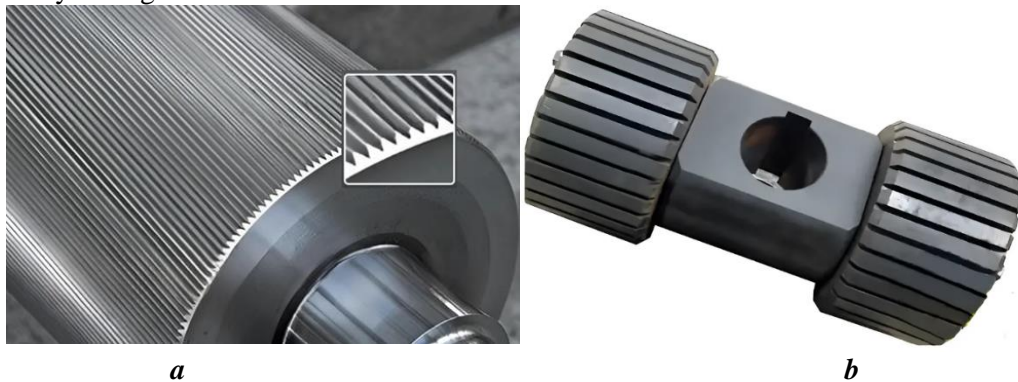

**Fig. 9. Rollers of flour milling and granulation equipment: a) – flour mill rollers; b) – granulator rollers**

Slotted joints can have different types of profiles, the choice of a specific profile depends on the strength requirements and other factors affecting the functionality of the joint.

Markoreliefs on the shells of fragmentation warheads are geometric features on their surface, specially created to optimize the mechanism of destruction during an explosion. These reliefs consist of a system of ridges and grooves located along the contour of the shell. When an explosive is triggered, they play the role of controlling the destruction mechanism, directing the energy of the explosion and maximizing the formation of fragments.



**Fig. 10. Fragmentation projectile**

Each of the methods of forming macoreliefs on the shells of shrapnel combat units or similar has its own unique characteristics that should be taken into account when choosing the optimal approach to processing materials.

Boring machines are known for their ability to create deep and detailed grooves, which can be important for certain applications that require a specific depth of relief. However, the process of working on turning machines can require considerable effort and time, which can complicate production processes.

Planers, on the other hand, typically provide a smooth surface with less roughness, which can be important for some applications where high surface quality is a priority. However, they can be less effective in creating complex shapes, and require specialized tools to achieve certain geometric configurations.

Multi-axis CNC lathes and milling machines open up wide possibilities for creating complex and detailed reliefs thanks to the software control of the movement of the tool. However, they can require significant hardware, cutting tool and programming costs, as well as specialized expertise to set up correctly and use effectively.



**Fig. 11. Types of cutters for gear cutting machines: a) – corn; b) – a shaper layer.**

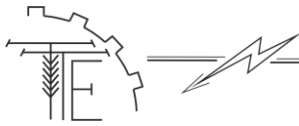

Gear cutting machines are known for their ability to provide a strong and stable relief, which can be important in demanding operating conditions. However, they can be limited in creating complex geometric surfaces and require specialized tools to achieve certain shapes.

It is worth noting that most of the milling cutters used on tooth-cutting machines have a corn-type macrorelief (Fig. 11, *a*).

As an example, controlled grooves make it possible to form cutting elements. A shaper (Fig. 11, *b*) used for performing intermediate and final planing operations, as well as for processing surfaces that have both curved and straight shapes, according to the established template.

In addition, this type of milling cutter is often used for processing arched decorative products, and finds its application in other areas of material processing.

The common disadvantages of these processing methods include the fact that they are all performed by cutting, without significant impact on the processed surface, which can reduce the effectiveness of using such reliefs, for more effective operation, it is necessary to change the material structure in the groove zone.

---

### 3. The purpose and objectives of the research

---

The purpose of the experimental study is to determine the potential possibilities of using macroreliefs in the nodes and mechanisms of machine-building and agricultural equipment to control fluid flows, reduce friction and wear, improve the functional characteristics of parts and increase their reliability and service life.

To achieve the set goal, you need to solve the following tasks:

- to analyze modern trends in mechanical engineering and agriculture related to the use of macrorelief;
- to compare the physical and mechanical properties of cylindrical parts with macroreliefs during deforming drawing
- determine the influence of the profile of macroreliefs on the performance characteristics of machine components, in particular, control of fluid flows and reduction of friction;
- to assess the effectiveness and practical application of the developed methods and technologies for the formation of macroreliefs in various industries;
- taking into account the received information, draw conclusions.

---

### 4. Results of the researches

---

Broaching machine with broaching is an important element of metal cutting equipment, which is used for processing through holes and outer surfaces of parts. Its functionality allows you to quickly and efficiently perform cutting, milling and processing of materials, ensuring high accuracy and quality of manufactured parts.

This tool is capable of working with many types of materials, including metals, plastics and composite materials, making it a versatile production tool. The use of a broaching machine with broaching allows you to increase processing productivity, reduce the time of manufacturing parts and ensure high quality of the final product.

In addition, this tool can be equipped with a variety of additional features, such as automatic control systems, cooling and lubrication systems, which further increase its efficiency and productivity. As a result, the broaching machine is an essential tool for production processes where it is important to achieve high speed and precision in processing parts.

The modern industry of tools in mechanical engineering and metalworking actively uses optimal designs of tools specially developed for the relevant production conditions [4]. This series includes combined broaches and other complex tools that work according to the kinematic broaching scheme. They are characterized by high productivity, as they can simultaneously operate many working edges, the total length of which can vary from several hundred to several thousand millimeters. Combined broaches can be the basis for creating tools for forming reliefs.

There are five types of broaching, depending on their configuration and the method of interaction with the part:

- 1) Round and slotted parts: The broaching type has a round shape at one end and a slotted shape at the other, allowing it to be used for machining parts with different types of holes or cutouts;
- 2) Slotted and round parts: The slotted shape is located closer to the end of the broach, which makes it easier to cut or mill parts with protrusions or protruding elements;
- 3) Round, slotted and chamfered parts: the broach has a round shape at one end, slotted at the other, and chamfered at the side, which allows cutting, milling and chamfering to be performed simultaneously;
- 4) Chamfered, round and slotted parts: the chamfered form is located closest to the end of the broach, which allows for chamfering, as well as cutting and milling;

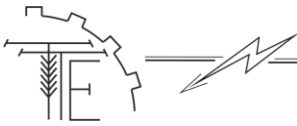

5) Chamfering, slotting and round parts: the chamfering part is also located closer to the end of the broach, which allows chamfering, cutting and milling to be performed with optimal efficiency.

Each type of broaching has its own characteristics and applications, which depend on specific production needs and requirements for processed parts.

For the most part, broaches are used in multi-series and mass production, which makes it a progressive metal-cutting tool of a highly specialized series, which is due to its high price.

The deforming-cutting broach (Fig. 12) consists of several main components. The first is the front shank (1), which serves as the basis for the entire structure. Next come the deforming elements (2), which are located among themselves and are separated by distance bushings (3), all these elements are strengthened on the mandrel (4). The last component is the cutting part (5), which is connected to the mandrel by welding.

- The following parts are distinguished in the drawing:
- front guide (A);
- deforming section (B);
- intermediate guide (C);
- draft (D);
- auxiliary (E);
- cleaning (F);
- calibrating (G) part of the cutting section (5);
- rear guide (H).

The cutting section is made of P6M5 high-speed steel according to the group scheme, taking into account the previous cold deformation hardening of the processing material (PM) and the parameters of the non-contact deformation wave. Longitudinal chip splitting in the case of drawing deep holes is also taken into account [4].

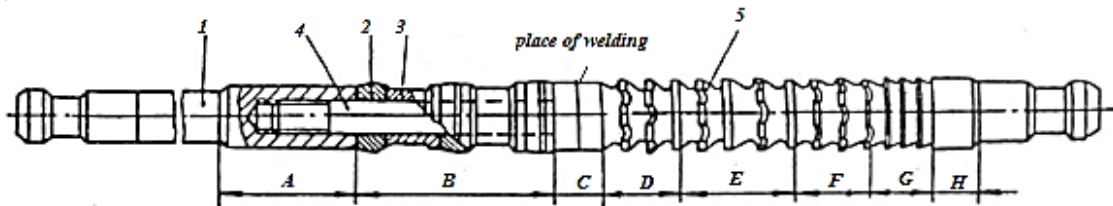

**Fig. 12. Deforming-cutting broaching.**

The method consists in the fact that one or two dividing elements 2 are installed on the drawing (Fig. 13) behind the deforming element 1 at an angle to the axis of the tool, the working edges 3 of which have the profile of the formed grooves.

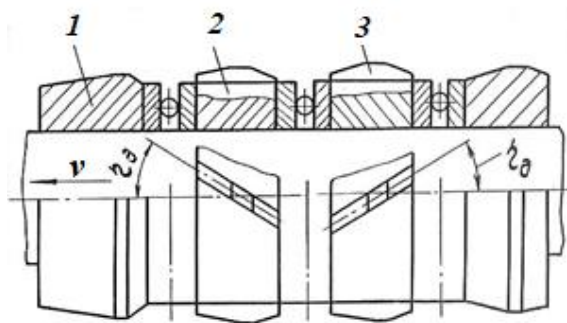

**Fig. 13. The working part of the broaching with deforming sections.**

Thanks to this, when these elements enter the hole, a tangential force occurs, under the action of which the element rotates, which makes it possible to provide a system of helical grooves, including intersecting ones, if necessary, and opens up new possibilities in metalworking.

For example, most types of firearms, with the exception of shotguns and special smoothbore weapons, have grooves in the middle of the barrel, fig. 14.

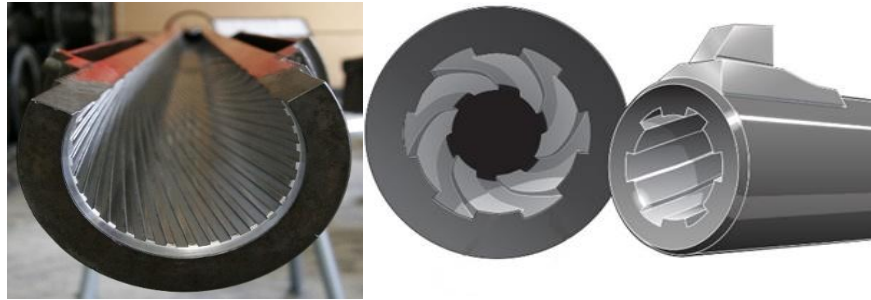

**Fig. 14. Macroreliefs on the elements of barrel weapons**

They ensure the rotation of the bullet, which, in turn, can have a similar relief to the barrel, in order to stabilize its movement during flight, which contributes to increasing the range and accuracy of shooting.

The rifling forms macroreliefs from spiral grooves cut inside the barrel, which works by rotating the projectile on its axis, causing gyroscopic forces that stabilize the rotation throughout flight; tight threads will spin the ball faster, while loose threads will spin the ball slower. The speed at which the ball spins is very closely related to how stable it will be; too slow and the bullet will flip in the air, too fast and the bullet may fly apart. The rate of rotation caused by rifling is determined by the pitch or rate of twist, their depth, and the shape of the rifling, which describes how loosely or tightly formed the rifling is inside the barrel of the weapon.

---

## 5. Conclusions

A broaching machine with a broaching machine is a key element of metal cutting equipment capable of processing through holes and external surfaces of parts. Its functionality allows you to quickly and efficiently perform cutting, milling and material processing operations with high precision and quality.

A broaching machine can work with a variety of materials, including metals, plastics and composites, making it a versatile tool for manufacturing needs. The use of a broaching machine with broaching allows you to increase the productivity of processing, reduce the time of manufacturing parts and ensure the high quality of the final product.

Modern industry actively uses optimal draft designs that allow to increase productivity and efficiency of processing.

There are five types of broaches depending on their configuration and method of interaction with the part, each of which has its own characteristics and application. Broaches are used mainly in multi-series and mass production, which is due to their high price and specialization in specific types of processing.

Deforming-cutting broaches consist of several components that ensure their functioning and efficiency in the processing process.

The method of using broaches with deformable sections allows obtaining macroreliefs on parts, which expands the possibilities of metalworking and ensures high quality and stability of products

## References

1. Paladiichuk, Y. (2021). Study of characteristics of growth formation after deformation strength during deforming strength. *Architecture Medical sciences Technical science Physics and mathematics*. №2 (89), 30–35. DOI: 10.24412/2520-2480-2021-289-30-36. [in English].
2. Shejkin, S.Ye., Studenec, S.F., Melnichenko, V.V., Melnichenko, Ya.V. (2016). Tehnologiya vidnovlennya kardannih valiv z zastosuvannyam gradiyentnogo deformacijnogo zmicnennya. *Visoki tehnologiyi v mashinobuduvanni*, 1 (26), 118–125. ISSN 2078-7677 [in Ukrainian].
3. Posviatenko E., Posviatenko N., Budyak, R., Shvets, L., Paladiichuk, Y., Aksom, P., Rybak, I., Sabadach, B., Hryhorychen, V. (2018). Influence of a material the technological factors on improvement of operating properties of machine parts by reliefs and film coatings. *Eastern-European Journal of Enterprise Technologies*, 5/12 (95), 48–56. ISSN 1729-3774. [in English].
4. Paladijchuk, Yu.B., Kordonskij, V.A. (2020). Obgruntuvannya mehaniki rujnuvannya struzhki pri protyaguvanni cilindrichnih poverhon z pripuskom. *Vibraciyi v tehnicji ta tehnologiyi*, 4 (99), S. 73–84. DOI: 10.37128/2306-8744-2020-4-9. [in Ukrainian].
5. Paladiichuk, Y. (2019). Forming of makroreliefiv is at reaching of internal surfaces of cylinder purveyance of power hydrocylinders. *Modern engineering and innovative technologies*, 10 (1), 74–79. ISSN 2567-5273. DOI: 10.30890/2567-5273.2019-10-01-012. [in English].



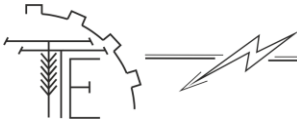

6. Skorkin, A.O., Kondratyuk, O.L., Shelkovij, O.M., Permyakov, O.A. (2017). Pidvishennya efektyvnosti protyaguvannya za rahunok kosokutnogo rizannya v zoni deformuvannya. *Mashinobuduvannya*, 20, 41–47. [in Ukrainian].
7. Nemyrovskiy, Ya., Shepelenko, I., Posviatenko, E., Tsekhanov, Yu., Polotnyak, S., Sardak, S., Paladiichuk, Y. (2020). Desining the structures of solid-alloy elements for broaching the holes of significant diameter based on the assessment of their strength. *Eastern-European Journal of Enterprise Technologies*, 3 (7-105), 57–65. ISSN 1729-3774. [in English].
8. Veselovska, N.R., Paladijchuk, Yu.B., Telyatnik, I.A. (2022). Doslidzhennya mikrotverdosti poverhni cilindrichnoi detali pri deformacijnomu protyaguvanni. *Tehnika, energetika, transport APK*, 3 (118), 31–42. DOI: 10.37128/2520-6168-2022-3-5. [in Ukrainian].

## ДОСЛІДЖЕННЯ ФОРМ І ПРИЗНАЧЕННЯ МАКРОРЕЛЬЄФІВ НА РОБОЧИХ ПОВЕРХНЯХ ЦИЛІНДРИЧНИХ ДЕТАЛЕЙ

Сучасні тенденції в машинобудуванні та сільськогосподарській промисловості підкреслюють важливість використання методів та засобів для поліпшення надійності окремих деталей та виробів в цілому, а також для зниження вартості продукції. Надійність деталей машин визначається рядом параметрів, таких як міцність, стійкість до зношування, вібраційна та термічна стійкість. Для досягнення цих критеріїв надійності деталей машин, необхідно враховувати різні методи виготовлення та вдосконалення технологій обробки матеріалів. Важливим аспектом є також використання композитних та інноваційних матеріалів, які можуть суттєво покращити характеристики виробів. Окрім того, впровадження автоматизації та цифрових технологій дозволяє оптимізувати виробничі процеси і зменшити ймовірність дефектів.

Дослідження форм та призначення макрорельєфів на робочих поверхнях циліндричних деталей є актуальною проблемою в галузі металообробки та машинобудування. Розгорнута анотація:

Предметом аналізу стали властивості та ефективність макрорельєфів у процесі металообробки, зокрема їх вплив на якість та функціональність виробів. Робота включає огляд різних типів макрорельєфів, їхнє призначення та застосування у виробничих умовах, з урахуванням конкретних вимог технологічного процесу.

Висвітлено методи формування макрорельєфів, включаючи технології обробки та їх вплив на технічні характеристики та якість кінцевого продукту. Результати дослідження показали, що використання макрорельєфів може покращити технологічні можливості обробки деталей, забезпечити підвищення їхньої міцності та стійкості, а також поліпшити зовнішній вигляд та естетичність виробу.

Отримані результати мають практичне значення для інженерів та дизайнерів, що займаються розробкою та виготовленням циліндричних деталей у різних галузях промисловості, таких як автомобілебудування, машинобудування, аерокосмічна та інші галузі, де важливо досягти оптимальної якості та ефективності виробництва.

**Ключові слова:** дослідження, макрорельєфи, робочі поверхні, циліндричні деталі, форми, призначення.

**Рис. 14. Літ. 8.**

### INFORMATION ABOUT THE AUTHORS

**Yuriy PALADIYCHUK** – Candidate of Technical Sciences, Associate Professor of the Department of Agroengineering and Technical Service of Vinnitsa National Agrarian University (3 Soniachna, St., Vinnitsa, 21008, Ukraine, e-mail: rewet@vsau.vin.ua, <https://orcid.org/0000-0003-4257-9383>).

**Artur HOROVYI** – Postgraduate, Vinnytsia National Agrarian University (Sonyachna str. 3, Vinnytsia, Ukraine, 21008). e-mail: artursukhopar5@gmail.com, <https://orcid.org/0009-0007-6177-6039>).

**ПАЛАДІЙЧУК Юрій Богданович** – кандидат технічних наук, доцент кафедри «Агроінженерії та технічного сервісу» Вінницького національного аграрного університету (вул. Сонячна 3, м. Вінниця, 21008, Україна, e-mail: rewet@vsau.vin.ua, <https://orcid.org/0000-0003-4257-9383>).

**ГОРОВИЙ Артур Володимирович** – аспірант, Вінницького національного аграрного університету (вул. Сонячна, 3, м. Вінниця, 21008, Україна, e-mail: artursukhopar5@gmail.com, <https://orcid.org/0009-0007-6177-6039>).